

A thesis entitled

CHEMICAL STUDIES OF SOME GRAM-NEGATIVE
BACTERIA AND THEIR INTERACTION
WITH ANTIBACTERIAL AGENTS

by

Yau Oi Ping

Submitted to the Faculty of Science for the
Degree of Doctor of Philosophy in the
University of London

Department of Chemistry,
Bedford College,
London N.W.1

March 1977

ProQuest Number: 10098333

All rights reserved

INFORMATION TO ALL USERS

The quality of this reproduction is dependent upon the quality of the copy submitted.

In the unlikely event that the author did not send a complete manuscript and there are missing pages, these will be noted. Also, if material had to be removed, a note will indicate the deletion.



ProQuest 10098333

Published by ProQuest LLC(2016). Copyright of the Dissertation is held by the Author.

All rights reserved.

This work is protected against unauthorized copying under Title 17, United States Code.
Microform Edition © ProQuest LLC.

ProQuest LLC
789 East Eisenhower Parkway
P.O. Box 1346
Ann Arbor, MI 48106-1346

Abstract

The growth of cells of Klebsiella aerogenes and Pseudomonas aeruginosa in the presence and absence of antibacterial agents was studied using microcalorimetry, with the concurrent measurement of such parameters as oxygen tension, pH, biomass and glucose concentration.

Cells of K. aerogenes growing in chemically-defined synthetic medium exhibited a characteristic thermogram (heat output-time curve). Oxygen depletion in the growing culture led to increasing fermentation, and growth ceased when the glucose was used up. Subsequently, acidic fermentation products were used as energy sources.

Sub-lethal concentrations of penicillin G, carbenicillin, methicillin, nalidixic acid, gentamicin, proflavine and sulphaniilamide all decreased the rate of growth of cells of K. aerogenes; the greater the concentration, the greater the effect. The pattern of the heat evolution of the growing cells was also altered by growth in the presence of the antibacterials, as compared with drug-free growth. Very pronounced changes in the heat output were observed at high drug concentrations. The results are discussed in terms of changes in metabolic pathways brought about by the presence of the drug. The effects of any given antibacterial was largely reduced when used against cells which had been trained to grow in the presence of that agent.

Cells of an R-factor mediated gentamicin-resistant strain of P. aeruginosa growing in synthetic medium exhibited a thermogram which was quite different from those of cells of three other strains

of differing sensitivity to gentamicin. Sub-lethal concentrations of gentamicin decreased the rate of growth of cells of P. aeruginosa strains and altered the pattern of heat output.

Small exothermic heat changes accompanied bacterial surface/gentamicin interactions.

Chemical analysis of whole cells of P. aeruginosa strains revealed differences in lipid, protein, amino acid and polysaccharide content between a very highly gentamicin-resistant strain and other resistant and sensitive strains.

This thesis comprises a report of full-time research undertaken by the author in the Physical Chemistry Laboratories of Bedford College, University of London, from January 1974 to January 1977.

Part of this work has been published by *Microbios*, ((1974), 11, 77). A further part has been accepted for publication by *Microbios*.

Acknowledgements

I would like to express my sincere thanks to Professor A. M. James, M.A., D.Phil., D.Sc., F.R.I.C., for his constant help and encouragement, which has made this work most enjoyable.

I am indebted to the University of London for financial assistance in the form of a Postgraduate studentship.

I also wish to thank the Academic and Technical staff of the Department of Chemistry, Bedford College, my research colleagues for their help and co-operation and Dr. M. McDonough of the Botany Department, Bedford College for assistance with amino acid analysis.

<u>CONTENTS</u>	Page
<u>ABSTRACT</u>	2
<u>ACKNOWLEDGEMENTS</u>	5
<u>SUMMARY</u>	9
<u>CHAPTER 1</u>	
<u>INTRODUCTION</u>	
1.1 Bacterial Classification	15
1.2 Bacterial Anatomy	17
1.3 The Gram-Negative Cell Envelope	20
1.4 Antibiotics and Antibacterial Agents	31
1.5 Resistance to Antibiotics and Antibacterial Agents	40
1.6 Microcalorimetry	43
1.7 Types of Calorimeter	46
1.8 Objects of the Investigation	50
<u>CHAPTER 2</u>	
<u>EXPERIMENTAL TECHNIQUES</u>	
2.1 Bacteriological Techniques	53
2.2 Microcalorimetry	59
2.3 Chemical Analysis of Whole Bacterial Cells	68

CHAPTER 3MICROCALORIMETRIC STUDIES OF THE GROWTH OF
CELLS OF K. AEROGENES IN DRUG-FREE MEDIUM

3.1	Growth of <u>K. aerogenes</u> in Synthetic Medium at 37 °C	78
3.2	Chemical Analysis of Supernatant	87
3.3	Summary	91

CHAPTER 4MICROCALORIMETRIC STUDIES OF THE GROWTH OF CELLS OF
K. AEROGENES IN THE PRESENCE OF ANTIBACTERIAL AGENTS

4.1	MIC Values of the Various Antibacterial Agents	94
4.2	Growth of Cells of <u>K. aerogenes</u> in the Presence of Penicillin G	95
4.3	Growth of Cells of <u>K. aerogenes</u> in the Presence of Methicillin or Carbenicillin	102
4.4	Growth of Cells of <u>K. aerogenes</u> in the Presence of Gentamicin	109
4.5	Growth of Cells of <u>K. aerogenes</u> in the Presence of Nalidixic Acid	115
4.6	Growth of Cells of <u>K. aerogenes</u> in the Presence of Sulphanilamide	120
4.7	Growth of Cells of <u>K. aerogenes</u> in the Presence of Proflavine	124
4.8	Summary	128

CHAPTER 5GROWTH OF CELLS OF P. AERUGINOSA IN THEPRESENCE AND ABSENCE OF GENTAMICIN

5.1	MIC of Gentamicin Values	131
5.2	Growth of Cells of Strains of <u>P. aeruginosa</u> in Drug-Free Medium	132
5.3	Growth of Cells of Strains of <u>P. aeruginosa</u> in the Presence of Gentamicin	143
5.4	Batch Calorimetry	153
5.5	Summary	154

CHAPTER 6CHEMICAL ANALYSIS OF WHOLE CELLS OFSTRAINS OF P. AERUGINOSA

6.1	Lipid Content of Cells of <u>P. aeruginosa</u>	156
6.2	Amino Acid Content of Cells of <u>P. aeruginosa</u>	158
6.3	Analysis of Protein, Polysaccharide and Nucleic Acid Content of Cells of <u>P. aeruginosa</u>	160
6.4	Summary	161

CHAPTER 7

<u>DISCUSSION</u>	162
-------------------	-----

<u>BIBLIOGRAPHY</u>	195
---------------------	-----

Summary

The heat changes accompanying growth of cells of Klebsiella aerogenes and Pseudomonas aeruginosa in synthetic medium (pH 7) and in medium containing different concentrations of antibacterial drugs at 37 °C were determined by microcalorimetry. Oxygen tension, pH changes, bacterial mass and glucose concentration in the medium were also monitored. The experimental arrangement was similar to that employed by Eriksson and Wadsö (1971).

When cells of K. aerogenes were grown in medium containing 2 g dm⁻³ of glucose, there was a smooth increase in heat output for about 2 h after inoculation. The rate of increase then fell to a lower level as the oxygen tension became reduced to about 15%. The heat output continued to rise at the new rate until the onset of the stationary phase, when heat output fell abruptly. A very slow decrease in heat output followed, until a second, sharper and larger decrease occurred. Oxygen tension decreased steadily, finally attaining a value of about 2-3% and remaining at this value until the second sharp decrease in heat output; at this point the oxygen tension rapidly regained a high value. The glucose concentration in the medium fell rapidly, becoming exhausted at the start of the stationary phase, suggesting that glucose is growth limiting. The final biomass was dependent on the glucose concentration of the medium. The pH of the growing culture decreased slightly until the first break in the thermogram (i.e. when the oxygen tension fell to 15%) and then decreased rapidly. This was probably due to the increasing amount of fermentation caused by oxygen depletion. After reaching a minimum value (about 5.5) at the onset of the stationary phase, the pH rose

steadily, apparently because the cells used acidic fermentation products as energy sources for secondary metabolism. However, the pH value never regained its initial value. Acetate was detected in the culture supernatant liquid, but the presence of lactate and pyruvate could not be demonstrated. The heat output and the total heat evolved, and the changes in the other environmental properties during growth in different concentrations of glucose are discussed in terms of metabolic processes occurring at different stages in the growth cycle.

When grown in the presence of sub-lethal concentrations of penicillin G, carbenicillin or methicillin, cells of K. aerogenes showed an initial brief growth phase, followed by a lag phase, the length of which increased with increasing concentration of antibiotic. Some cell lysis occurred after the initial growth phase. This growth and lysis is explicable in terms of the actions of the penicillins; these antibiotics are taken up by growing cells and interfere with wall synthesis, thereby weakening the cell wall. After the lag phase the cells resumed growth at a lower rate; the evolution of heat was reduced as compared to drug-free growth. The total biomass was unaffected by growth in penicillin G or carbenicillin; methicillin caused a reduction of biomass. Cells with in vitro resistance to the antibiotics, gave results (heat output and changes in environmental properties) when growing in the presence of these antibiotics, similar to those of untrained cells grown in drug-free medium. This increase in tolerance may come about either by changes of metabolic pathway or as a result of chromosomal mutation.

Gentamicin at concentrations of $\frac{1}{2}$ x MIC and 2 x MIC caused

a reduction in growth rate (proportional to concentration of antibiotic) before maximum growth of cells of K.aerogenes was reached. The pattern of evolution of heat was altered compared with drug-free medium; the biomass was unaltered. When a gentamicin concentration of 4 x MIC was used an initial phase of growth was followed by a lag phase. A considerable evolution of heat was detected during the lag phase before growth (or a fall in oxygen tension) resumed. The presence of the antibiotic increased the total heat evolution compared with that for drug-free growth. The heat output and total heat evolved by gentamicin-trained cells growing in the presence of gentamicin were very similar to the corresponding values for the control cells.

When cells of K. aerogenes were grown in the presence of 5 x MIC and 7 x MIC of nalidixic acid the shape of the thermogram was markedly different to that exhibited by the control cells growing in drug-free medium. A second peak in heat output occurred after the start of the stationary phase. The total heat output was less than for the growth of control cells.

The length of the lag phase and mgt were also increased by growth in the presence of $\frac{1}{2}$ x MIC of proflavine. No secondary metabolism of fermentation products was observed with cells growing in the presence of proflavine, and the thermogram differed from the normal thermogram accordingly. The total heat evolved did not differ significantly from that during growth in drug-free medium. Cells trained to proflavine were relatively unaffected by subsequent growth in the presence of the drug; the presence of secondary metabolic processes was now evident.

The presence of sulphanimide in the growth medium at concentrations of $\frac{1}{2}$, 2 and 3 x MIC resulted in increased mgt values. Biphasic growth was observed. The shape of the thermogram was also altered compared with that for drug-free growth; a second peak in heat output occurred after the onset of the stationary phase. The pattern of heat evolution was altered during the different parts of the growth cycle as compared with normal growth; the total heat evolved was increased by growth at the highest concentration of sulphanimide used. The thermogram of trained cells was similar to that of the control.

Cells of P. aeruginosa grew more slowly in drug-free synthetic medium than cells of K. aerogenes. The thermograms showed an increasing heat output during the first phase of exponential growth. Cells of two of the four strains examined showed a sharp decline in the rate of increase of heat output when the oxygen tension was about 15%. For cells of two highly-gentamicin resistant and one gentamicin-sensitive strain the heat output fell sharply to a plateau value as the oxygen tension in the culture became depleted. A second rapid fall in heat output corresponded to the onset of the stationary phase, the depletion of glucose in the medium, and a marked increase in the oxygen tension. For an R-factor mediated gentamicin-resistant strain, the heat output fell sharply (without giving a plateau value) when the oxygen tension showed a marked increase from a very low value and as the glucose concentration became exhausted.

The growth of cells of all four strains at a gentamicin concentration of 4 x MIC, resulted in an increased length of lag

phase. In the presence of gentamicin the shape of the thermogram of the most highly resistant strain changed to a form similar to that of the R-factor strain. Thus the maximum heat output corresponded to the onset of the stationary phase with no subsequent plateau heat output. The total heat evolved by the R-factor carrying strain was increased during growth in the presence of the drug, but was unchanged for the other three strains.

The results of batch-cell microcalorimetry indicated a small exothermic reaction between cells of either K. aerogenes or three P. aeruginosa strains and molecules of gentamicin. The highly resistant P. aeruginosa strain 100 gave the smallest heat of reaction with gentamicin, but it is not known whether this has any bearing on its level of resistance.

A chemical analysis was made of whole cells of gentamicin-sensitive and gentamicin-resistant strains of P. aeruginosa. The most highly resistant strain had a higher ratio of neutral lipid to phospholipid than did the other strains, although all the strains had an approximately equal amount of total cell lipid. Analysis also showed that all the cells had essentially the same content of RNA and DNA. The most highly resistant strain (strain 100) again differed from the other strains in having a higher polysaccharide content and a lower protein content than these strains. This latter finding was confirmed by an amino acid analysis of the strains, strain 100 having a significantly lower content of each of the amino acids than the other strains. These differences may reflect a different mechanism of resistance between the other resistant strains and strain 100.

CHAPTER 1

INTRODUCTION

1.1 Bacterial Classification

Micro-organisms may be divided into eight major groups: algae, bacteria, moulds, pleuropneumonia-like-organisms (PPLO), protozoa, rickettsia, viruses and yeasts. Distinct characteristics determine inclusion in a particular group, although the borders between the groups are diffuse and the subject of much discussion.

The bacteria are normally divided into ten orders (Table 1.1), and the orders divided into families. Membership within a family is determined by factors such as cell shape, motility and if motile the presence or absence of flagella, reaction to the Gram stain, growth requirements, optimum temperature of growth, the type of fermentations which the cultures are able to carry out under anaerobic and aerobic conditions etc.. The Gram stain is used as a preliminary characterisation technique, organisms being described as Gram-negative, Gram-positive or Gram-variable depending on their ability to retain crystal violet dye after mordanting with iodine solution. Cell morphology and whether or not cells possess spores, is revealed by the Gram stain.

Klebsiella aerogenes, one of the organisms used in this study, is a Gram-negative, non-motile, non-spore-forming rod which ferments glucose, lactose and other sugars, with the production of acid and gas (gas ratio : two or more volumes of CO₂ to one volume of H₂ are produced from glucose). It is aerobic or facultatively anaerobic, with an optimum growth temperature of about 30 °C, is frequently encapsulated, is catalase positive and gives a positive Voges-Proskauer test. Colonies grown on agar are white, smooth, raised convex and often mucoid.

Table 1.1

Bacterial classification with particular reference to
Klebsiella and Pseudomonas

<u>Order</u>	<u>Family</u>	<u>Genus*</u>
Hyphomicrobiales		
Clamydobacteriales		
Eubacteriales	9 families including	
Actinomycetales	Enterobacteriaceae	Klebsiella
Caryoplanales		
Pseudomonadales	Pseudomonadaceae	Pseudomonas
Beggiatoales	Spirillaceae	
Myzobacteriales		
Spirochaetales		
Mycoplasmatales		

<u>* Genus</u>	<u>Sub-generic group</u>	<u>Species</u>
Klebsiella		<u>K. aerogenes</u>
Pseudomonas	Fluorescent	<u>P. fluorescens</u>
	Alcaligenes	<u>P. putida</u>
	Acidovorans	<u>P. aeruginosa</u>

K. aerogenes is widely distributed in nature, being found in the intestinal tracts of man and other animals, in water, milk, dairy products and plant material.

Pseudomonas aeruginosa, the second organism used in this investigation, is a Gram-negative, non-spore-forming rod ($1.5 \times 0.5 \mu\text{m}$) which is motile by means of a polar flagellum. It grows aerobically between 5 and 43°C utilising a wide range of energy sources and produces two water soluble pigments (fluorescein and pyocyanine) as well as a characteristic odour. It is usually non-capsulate and is sometimes fimbriated. It can produce acid oxidatively from glucose, rapidly liquefies gelatin and gives a positive oxidase reaction. The colonies are greyish, large, low convex with an irregular, translucent, spreading edge.

As a pathogen P.aeruginosa is often a cause of urinary tract, respiratory tract and ear and eye infections and infections due to catheterisation or other diagnostic or therapeutic instrumentation. It frequently infects burns and deep wounds and causes acute purulent meningitis following cranial injury or accidental introduction after lumbar puncture. These infections are usually localised but with debilitated persons or infants, an invasion of the blood stream may occur, resulting in a fatal generalised infection.

1.2 Bacterial Anatomy

Figure 1.1 shows a cross-section through a typical bacterial cell, revealing the basic cellular organisation. The cytoplasm is

Figure 1.1

Diagrammatic representation of
a cross-section through a bacterial cell

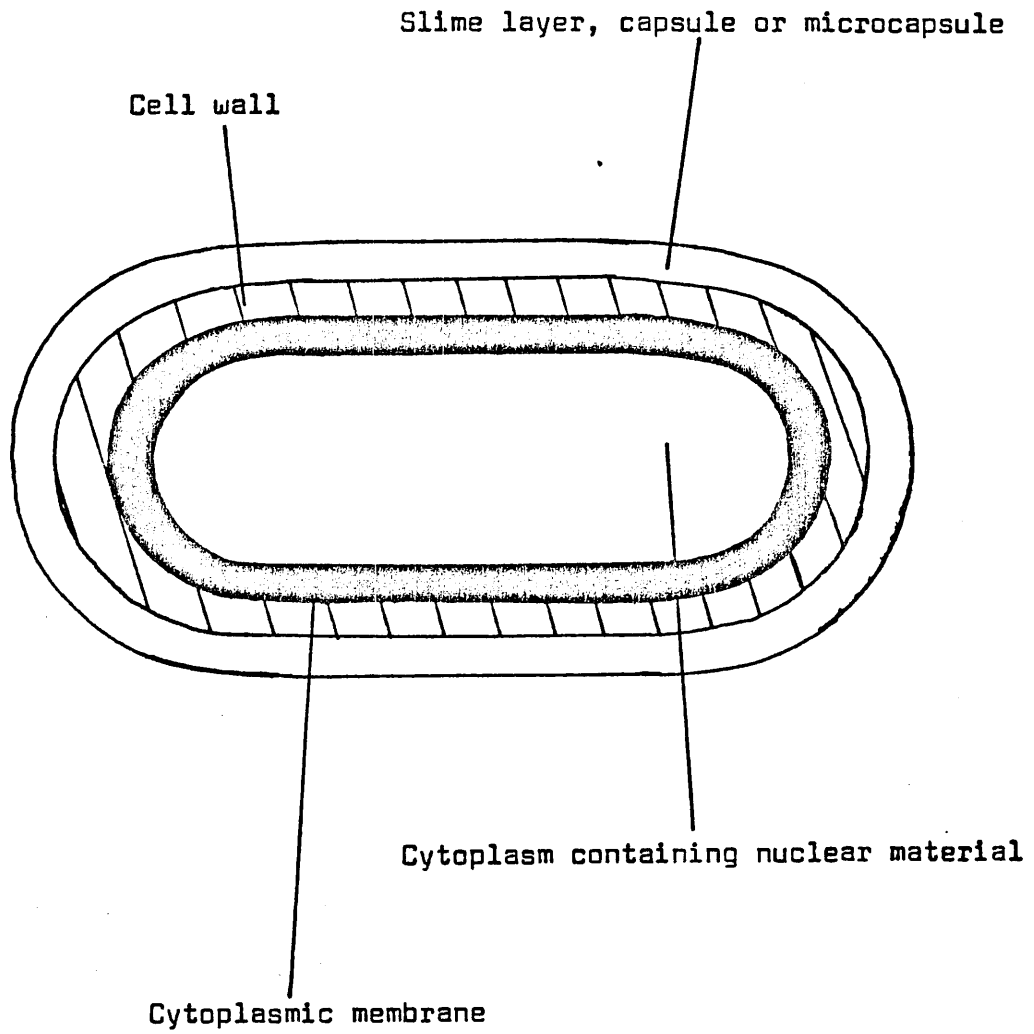

surrounded by a cytoplasmic membrane, which is in turn surrounded by a cell wall. In many organisms a slime layer or capsule envelops the cell. Surface appendages may also be present.

The cytoplasm is a slightly viscous colloidal complex, formed from water, proteins, fats, amino acids, carbohydrates and inorganic material, often having stored nutrients and oil suspended in it. Ribosomes in the cytoplasm are the site of protein synthesis. Often many ribosomes are attached to one molecule of ribonucleic acid. The ribosomes and storage particles give the cytoplasm a granular appearance. The nuclear material, or nucleoid, lies in the cytoplasm and is not bounded by a nuclear membrane.

Flagella are thread-like structures which bring about cell motility by their motion, as well as being the site of the H-antigens. P. aeruginosa has a single, polar flagellum, which protrudes through the cell surface whilst being continuous with the cytoplasm. Flagella are composed almost entirely of a protein called flagellin. Fimbriae or pili are fine, hair-like surface appendages which are known to confer adhesive, haemagglutination and antigenic properties to bacterial cells.

Many bacteria have slime layers or capsules surrounding them, lying external to the cell wall and in close contact with it. The amount produced depends on the nature of the growth medium and unfavourable growth conditions may stimulate the production of such layers. In pathogenic forms, capsules are often correlated with virulence. Gram-negative species have chemically more complex capsules composed of polysaccharide, protein-polysaccharide and lipo-polysaccharide complexes, than do Gram-positive species

(e.g. Staphylococcus aureus) which have capsules composed of simple polysaccharides and occasionally polypeptides.

1.3 The Gram-Negative Cell Envelope

The outer layers of Gram-negative bacteria are composed of several discrete macromolecular components. However, the organisation of these components is not fully understood; some layers are intimately associated with neighbouring structures. Because there are no clear boundaries between different structures, all structures external to the cytoplasm, including the cytoplasmic membrane, are considered as a single multi-layered unit termed the cell envelope.

The cell envelope surrounds the bacterial protoplast, and being rigid, it gives a microbial cell its particular shape. It is also the permeability barrier between environment and cytoplasm, and is responsible for antigenicity and the response to pyocines and bacteriophages. The envelope can also withstand osmotic pressure. In Gram-negative bacteria, the osmotic pressure across the cytoplasmic membrane is generally about 12 atmospheres, whilst the Gram-positive cell wall is capable of withstanding pressures of up to 30 atmospheres.

The main classes of chemical constituents found in Gram-negative cell envelopes are proteins, lipids, peptidoglycans, polysaccharides, lipopolysaccharides and lipoproteins. Unlike Gram-positive cell walls (which may contain as few as three amino acids), Gram-negative cell envelopes contain a wide range of amino acids

(up to 21), similar to that found in most proteins (Salton, 1952).

Chemical analysis and electron microscopy have advanced the state of knowledge of the structure and composition of the Gram-negative cell envelope to a point where the different layers can be discussed in some detail. A model for the Gram-negative envelope proposed by Costerton et al (1974), is shown in Figure 1.2. The envelope is considered to consist of the cytoplasmic membrane, outside which is the periplasmic space containing the peptidoglycan layer, and outside this space is a second, outer membrane.

1.3.(a) Cytoplasmic Membrane

Pure preparations of Gram-negative bacterial cytoplasmic membranes have been isolated and found to have similar chemical composition to that of other biological membranes (Schnaitman, 1970b; Martin and MacLeod, 1971 and White et al, 1972). Freeze-etching studies have shown that the frozen membrane fractures along a median hydrophobic zone (Bayer and Remsen, 1970). De Voe et al (1971) have reported that this hydrophobic layer is traversed by protein 'studs' which may be involved with the transport of substrates. The continuous phospholipid bilayer may contain structural membrane protein, whilst other protein may be attached to the inner and outer faces of the membrane by hydrophobic interactions.

As well as being the site of biosynthesis of wall polymers, the cytoplasmic membrane is also the site of other activities such as oxidative phosphorylation. Thus many of the membrane proteins

Figure 1.2

Schematic diagram of Gram-negative cell envelope

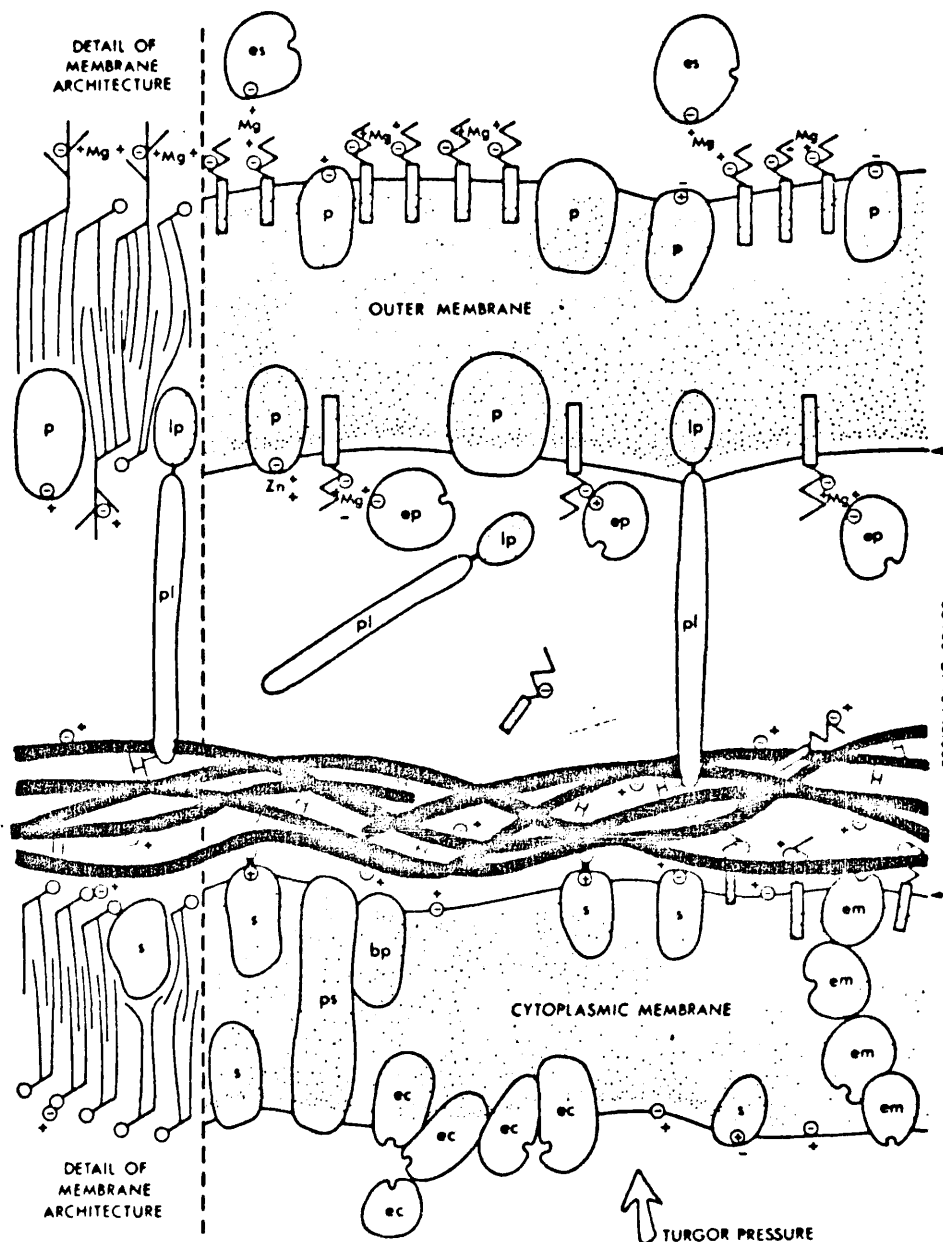
(Costerton *et al*, 1974)

+, Free cation; -, free anion; ⊕ bound cation; ⊖ bound anion; ⚡ adhesion point produced by ionic bonding; ⚡ hydrophobic zone; — covalent bond; — cross-linking polypeptide in the peptidoglycan; — polysaccharide portion of peptidoglycan; — enzymatically active protein; — phospholipid; — lipopolysaccharide; — lipopolysaccharide (schematic); bp, binding protein; ec, enzymes associated with the cytoplasmic membrane whose function is directed to the cytoplasm; em, enzymes associated with the cytoplasmic membrane which synthesize macromolecular components of the cell wall; ep, enzymes localized in the periplasmic zone; es, enzymes localized at the cell surface; lp, lipid portion of Braun's lipoprotein; p, structural and enzymatic proteins of the outer membrane; pl, protein portion of Braun's lipoprotein; ps, permease; s, structural protein of cytoplasmic membrane.

must be enzymes involved in these processes.

1.3.(b) Peptidoglycan-lipoprotein complex

Outside the membrane is the peptidoglycan layer, although there may be a periplasmic region between the two layers (Figure 1.2). Peptidoglycan is present in highly variable amounts in Gram-negative organisms, although on average it constitutes about 10% by weight of the cell envelope, as compared to 40-90% of the Gram-positive wall. The peptidoglycan layer is about 2-3 nm thick in the Gram-negative envelope and about 20-80 nm thick in the Gram-positive wall. This suggests a two dimensional monolayer structure in the former and a three dimensional structure in the latter (Ghuysen, 1968; Keleman and Rogers, 1972).

A major function of the peptidoglycan layer is to give the bacterium shape and mechanical strength. Forsberg et al (1970a) have demonstrated that cells bounded only by their peptidoglycan layer will maintain their shape, even though other cell layers may contribute to cell rigidity or maintain cellular shape (Carson and Eagon, 1966; Cox and Eagon, 1968 and Henning et al, 1973).

A number of workers (Strominger et al, 1959; Mandelstam and Rogers, 1959; Rogers and Perkins, 1959; Hancock, 1960; Mandelstam and Strominger, 1961) have helped to elucidate the structure of peptidoglycan. Weidel et al (1960) isolated Gram-negative peptidoglycan and its structure was found to be very similar to that in Gram-positive cells. Peptidoglycan consists of a polysaccharide

backbone of alternating β -1, 4-linked N-acetyl glucosamine and N-acetyl muramic acid residues (Figures 1.3 and 1.4). Peptide subunits are attached to the N-acetyl muramic acid molecules, consisting of L-alanine, D-glutamic acid, diaminopimelic acid (or L-lysine, its decarboxylation product) and D-alanine (Figure 1.5). The peptide chains are often joined via peptide bridges, although in the case of Escherichia coli and probably of P. aeruginosa the linkage is by direct bonding between the D-alanine of one subunit and the (D)-asymmetric carbon atom of the meso-diaminopimelic acid of its neighbouring subunit. In Gram-negative cells the arrangement of cross-linked peptide subunits is probably random, giving a loose network, whereas a more rigid structure is formed in some Gram-positive organisms by all the peptide subunits being cross-linked.

A lipoprotein extends from the peptidoglycan to the outer cell membrane in several enteric bacteria (Braun and Rehn, 1969; Braun et al, 1970; Braun and Sieglin, 1970; Braun and Wolff, 1970; Braun and Bosch, 1972) and this may serve to link the peptidoglycan to the outer layers of the wall, thus giving a rigid foundation for the whole cell envelope.

1.3.(c) Periplasmic Zone

The periplasmic zone is bounded on either side by the double membrane structures of the cytoplasmic membrane and the outer membrane layer. The peptidoglycan layer is contained within the periplasmic zone.

Figure 1.3

A schematic representation of the peptidoglycan of
the cell envelope of Escherichia coli

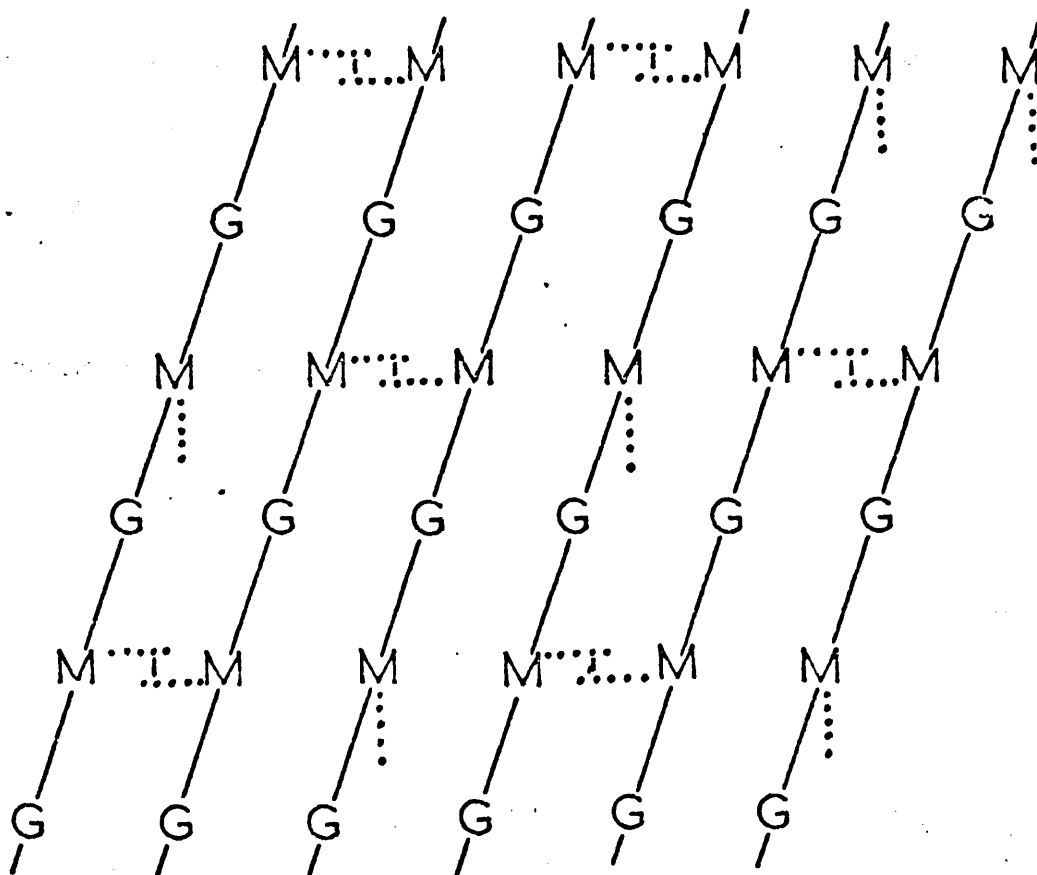

Key

Glycan chains composed of:

- G** N-acetylglucosamine
M N-acetylmuramic acid

Vertical dots represent peptide subunits attached to N-acetylmuramic acid. Horizontal dots represent peptide subunits cross-linking between adjacent glycan strands.

Figure 1.4

A portion of the glycan strand of peptidoglycan showing the
site of attachment of the peptide subunit

Key

N - Ac Glu	=	N-acetylglucosamine
N - Ac Mur	=	N-acetylmuramic acid

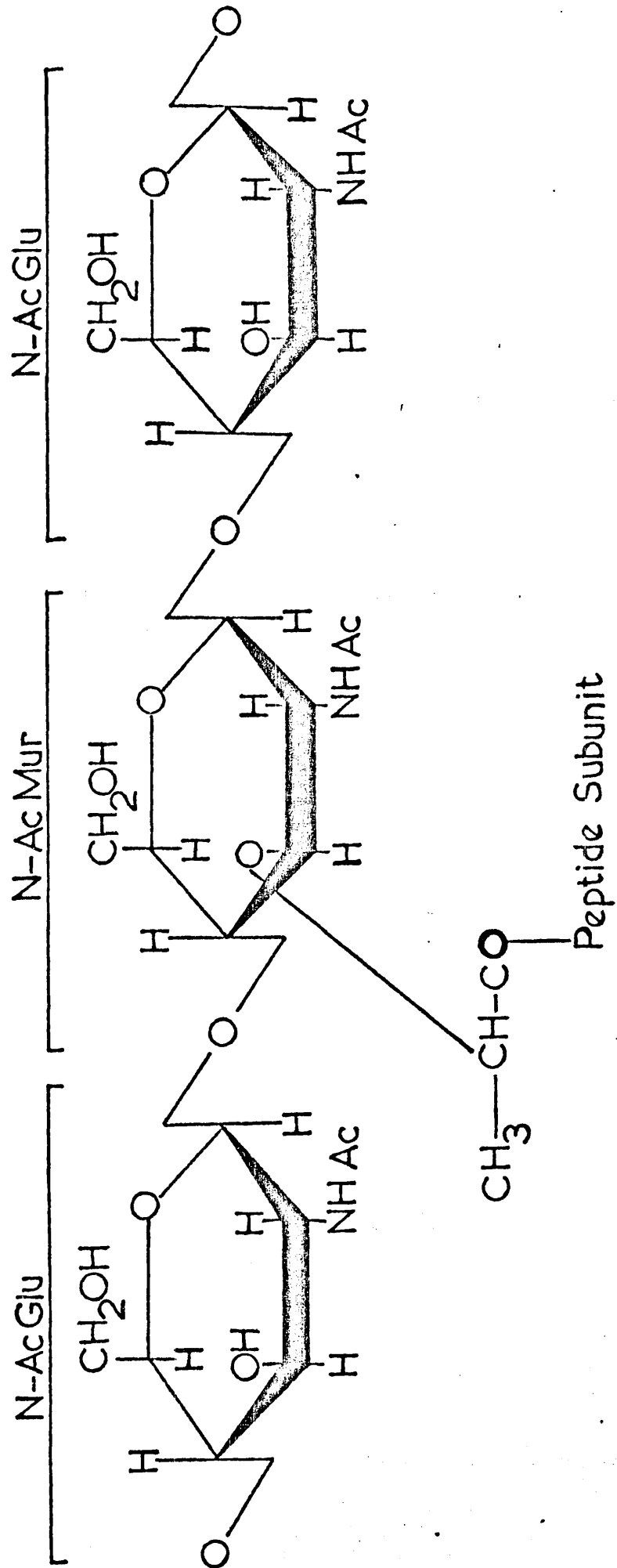
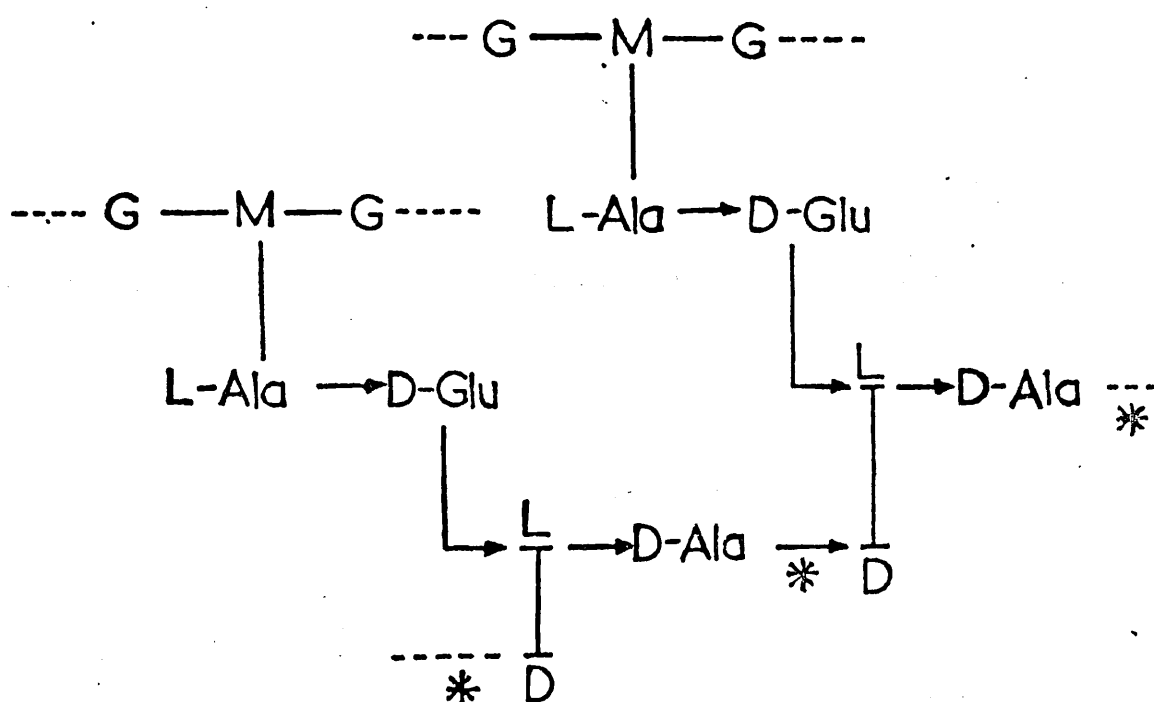

Figure 1.5

The structure of the peptide subunits of peptidoglycan showing
the site of cross-linking between adjacent glycan strands
of N-acetylglucosamine and N-acetylmuramic acid



Key

G	N-acetylglucosamine	M	N-acetylmuramic acid
L-Ala	L-alanine	D-Ala	D-alanine
D-Glu	D-glutamic acid	*	Site of cross-linking
$\begin{array}{c} \text{L} \\ \\ \text{D} \end{array}$	Meso-diaminopimelic acid, with asymmetric carbon atoms designated L and D.		

A number of periplasmic enzymes, binding proteins and pigments are released during experiments in which the permeability of the outer cell membrane has been altered, for example by exposing cells of P. aeruginosa to $0.2 \text{ mol dm}^{-3} \text{ Mg}^{2+}$ or growing cells at elevated pH (Cheng et al, 1970).

1.3.(d) Outer Membrane Layer

The outer membrane layer is known to contain phospholipid, protein and variable amounts of lipopolysaccharide (Forsberg et al, 1970a,b; Schnaitman, 1970a,b; DePamphilis and Adler, 1971; Osborn, 1971; Rothfield and Romeo, 1971; Schnaitman, 1971; Osborn et al, 1972a,b; White et al, 1972). The proteins and phospholipids appear to form the body of the membrane, with the oligosaccharide part of the lipopolysaccharide associated with the inner and outer surfaces (Cheng et al, 1971; Schnaitman, 1971). Electron micrographs of embedded and sectioned cells reveal a profile similar to that of other biological membranes, suggesting that the phospholipids and proteins form a bilayer. In freeze-etching studies, a cleavage plane in the membrane was observed (Dvorak et al, 1970; DeVoe et al, 1971; Gilleland et al, 1973), suggesting that the hydrophobic portions of the phospholipid and lipopolysaccharide molecules form a central zone, similar to that found in other membranes. It has also been shown with freeze-etching studies that the outer membrane of P. aeruginosa contains a granular subunit, which is predominantly proteinaceous (Lickfield et al, 1972; Gilleland et al, 1973) and

which is removed on exposure to Tris-EDTA. Osborn et al (1972b) have reported phospholipase activity in one outer membrane protein.

Divalent metal ions are important in maintaining the integrity of the envelope and also in retaining outer cell membrane lipopolysaccharide (Eagon et al, 1965; Wilkinson, 1967; Leive, 1968; Wilkinson, 1970; O'Leary et al, 1972). It has been proposed that the divalent metal ions are involved with phosphate groups in the cross linkage of lipopolysaccharide groups in the cell envelope and thus help to maintain envelope integrity (Roberts et al, 1970; Wilkinson, 1970).

The Costerton model (Costerton et al, 1974) envisages the lipid A portions of the lipopolysaccharide molecules associated with the hydrophobic zone of the outer membrane in such a way that the oligosaccharide portions of the lipopolysaccharide molecules form a 'picket-fence', protruding from the inner and outer membrane surfaces and carrying the 'O' antigen at their distal tips (Figure 1.2). It is further proposed that the polysaccharide chains form an ordered and cross-linked mass, this interaction thus helping to strengthen the cell envelope. The phospholipids and proteins of the basic outer membrane are then exposed (possibly as specific receptor sites) to varying degrees between the oligosaccharide chains. These receptor sites might be phospholipid with the polar heads at the surface (Glauert and Thornley, 1969), specialised lipopolysaccharide (phage receptors, Lindberg and Hellerquist, 1971) and glycoprotein (colicin receptors, Sabet and Schnaitman, 1973).

The external position of the outer membrane layer makes it responsible for some of the properties of the intact cell.

It must play some part in transport, acting as a barrier which excludes a wide variety of molecules from the cell. It also retains enzymes and structural components within the periplasmic space (Costerton et al, 1974).

1.4 Antibiotics and Antibacterial Agents

Antibiotics are defined as compounds produced by micro-organisms, which at low concentrations inhibit the growth and other activities of other micro-organisms.

The structure of penicillin is shown in Figure 1.6. variation in the side chain R causes alteration of the properties of the molecule. Benzylpenicillin (penicillin G) is the most commonly used form of penicillin (Figure 1.6).

The mechanism of action of the penicillins is to interfere with bacterial cell wall synthesis, inhibiting the formation of the penta-glycyl peptide cross-linkages without interfering with protein synthesis in S. aureus (Mandelstam and Rogers, 1959). This weakening of the cell wall polymer results in the high osmotic pressure inside the cell pushing the protoplasmic membrane through the weakened cell wall and lysis results. This penicillin induced lysis only occurs with actively growing cells. The penicillin group of antibiotics is generally not as effective against Gram-negative bacteria which contain less peptidoglycan in their cell walls, than do Gram-positive organisms.

The β -lactam ring of benzylpenicillin is easily opened

Figure 1.6

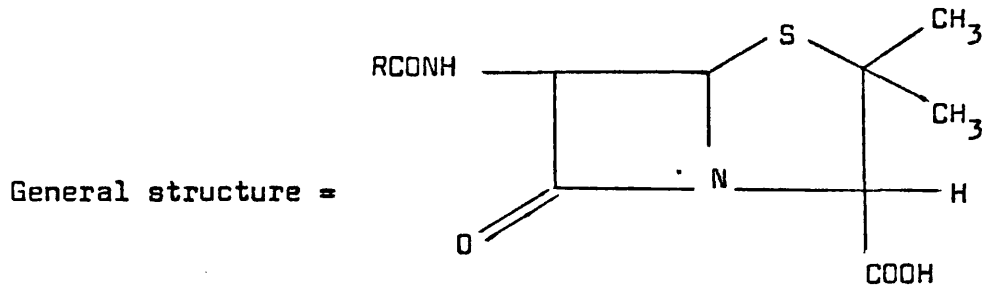
The molecular structure of some penicillins

Benzyl penicillin (G),

R =

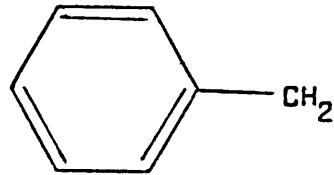

Methicillin ,

R =

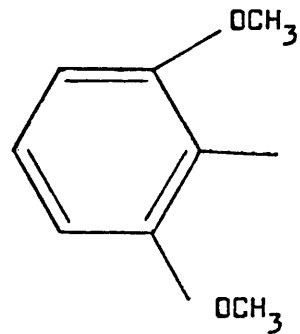

Carbenicillin,

R =

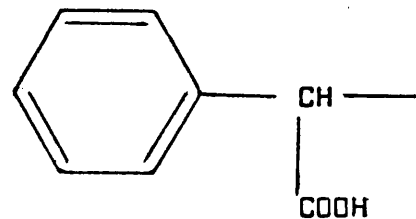

by the action of penicillinase (β -lactamase) enzymes to give the biologically inactive penicilloic acid (Figure 1.7). Over the last few years the use of benzylpenicillin has decreased since the isolation of the penicillin nucleus (6-aminopenicillanic acid) by Batchelor et al (1959). The relatively large quantities of this substance available have made possible the synthesis of very many semi-synthetic penicillins, in which the side chain has been modified from that of benzylpenicillin. Important considerations in the search for new penicillins have been to produce molecules which (a) are resistant to microbial β -lactamase enzymes, (b) have a larger spectrum of activity than benzylpenicillin, (c) are stable to acid and (d) have a low degree of binding to serum proteins (Price, 1969).

Simple α -substitution of the benzylpenicillin with a carboxyl group produced a marked increase in activity against Gram-negative organisms (including β -lactamase producers) compared with benzylpenicillin. The structure of this resulting antibiotic, carbenicillin (disodium- α -carboxybenzylpenicillin) is shown in Figure 1.6. This antibiotic, which like the other penicillins interferes with cell wall synthesis, has been used with some success against Gram-negative bacteria, especially P. aeruginosa. However, resistance quickly develops and for this reason it is often used in combination with gentamicin.

A large group of penicillins has the carbonyl group substituting the amino group of 6-aminopenicillanic acid directly attached to a carbocyclic or heterocyclic ring. Ortho-substituents in this ring give a measure of steric hindrance around the amide link which greatly reduces the affinity for the active site of

Figure 1.7

The hydrolysis reaction which brings about
the inactivation of penicillin

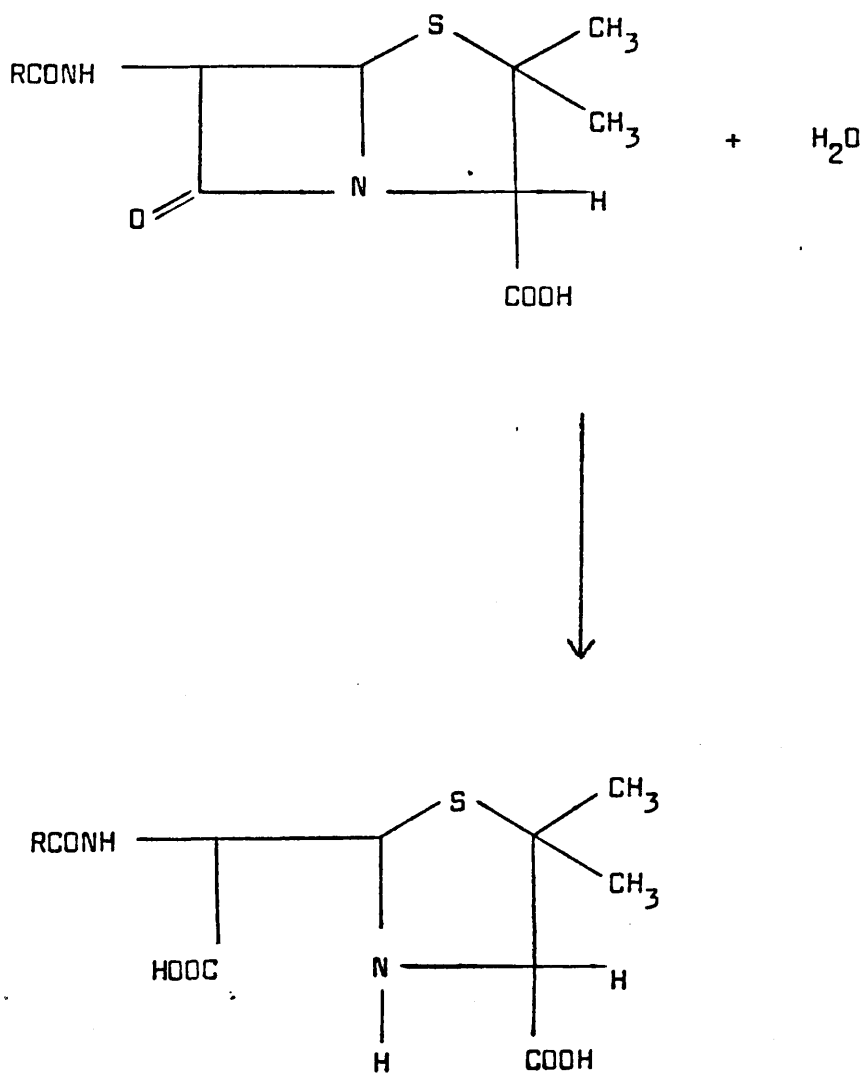

staphylococcal β -lactamases. Two small substituents such as are found in methicillin or 2,6-dimethoxy-phenylpenicillin (Figure 1.6) give the best results. Methicillin was the first penicillin reported to show good activity against penicillin-resistant staphylococci (penicillinase producers) both in vivo and in vitro (Rolinson et al, 1960).

Gentamicin is an aminoglycoside antibiotic, other members of this group including neomycin, kanamycin and streptomycin. The structure of the gentamicins is shown in Figure 1.8. The antibiotic is obtained from submerged cultures of Micromonospora purpurea; commercial preparations are a mixture of the three components, gentamicins C₁, C_{1a} and C₂, in approximately equal proportions (gentamicin A is not present in commercial preparations).

Gentamicin is very effective against P. aeruginosa (as well as many other Gram-negative and Gram-positive bacteria) and is most frequently used in infections caused by this organism (Weinstein et al, 1963; Barber and Waterworth, 1966). In common with other aminoglycoside antibiotics it has the disadvantage of being ototoxic and thus dosage must be carefully controlled.

The mechanism of action of gentamicin is in its interference with protein synthesis, causing misreading and inhibition of peptide bond formation, probably by interacting with ribosome components, and leading to cell death (Davies and Nomura, 1972).

Nalidixic acid (Figure 1.9) is a specific and effective inhibitor of deoxyribonucleic acid (DNA) synthesis in bacteria (Goss et al, 1965). Crumplin and Smith (1976) have reported that

Figure 1.8

The structures of the gentamicins

	<u>Key</u>					
	<u>R₁</u>	<u>R₂</u>	<u>R₃</u>	<u>R₄</u>	<u>R₅</u>	<u>R₆</u>
Gentamicin A	H	OH	OH	OH	H	OH
C _{1a}	H	NH ₂	H	H	OH	CH ₃
C ₂	CH ₃	NH ₂	H	H	OH	CH ₃
C ₁	CH ₃	NHCH ₃	H	H	OH	CH ₃

A = purpurosamine ring

B = deoxystreptamine ring

C = garosamine ring

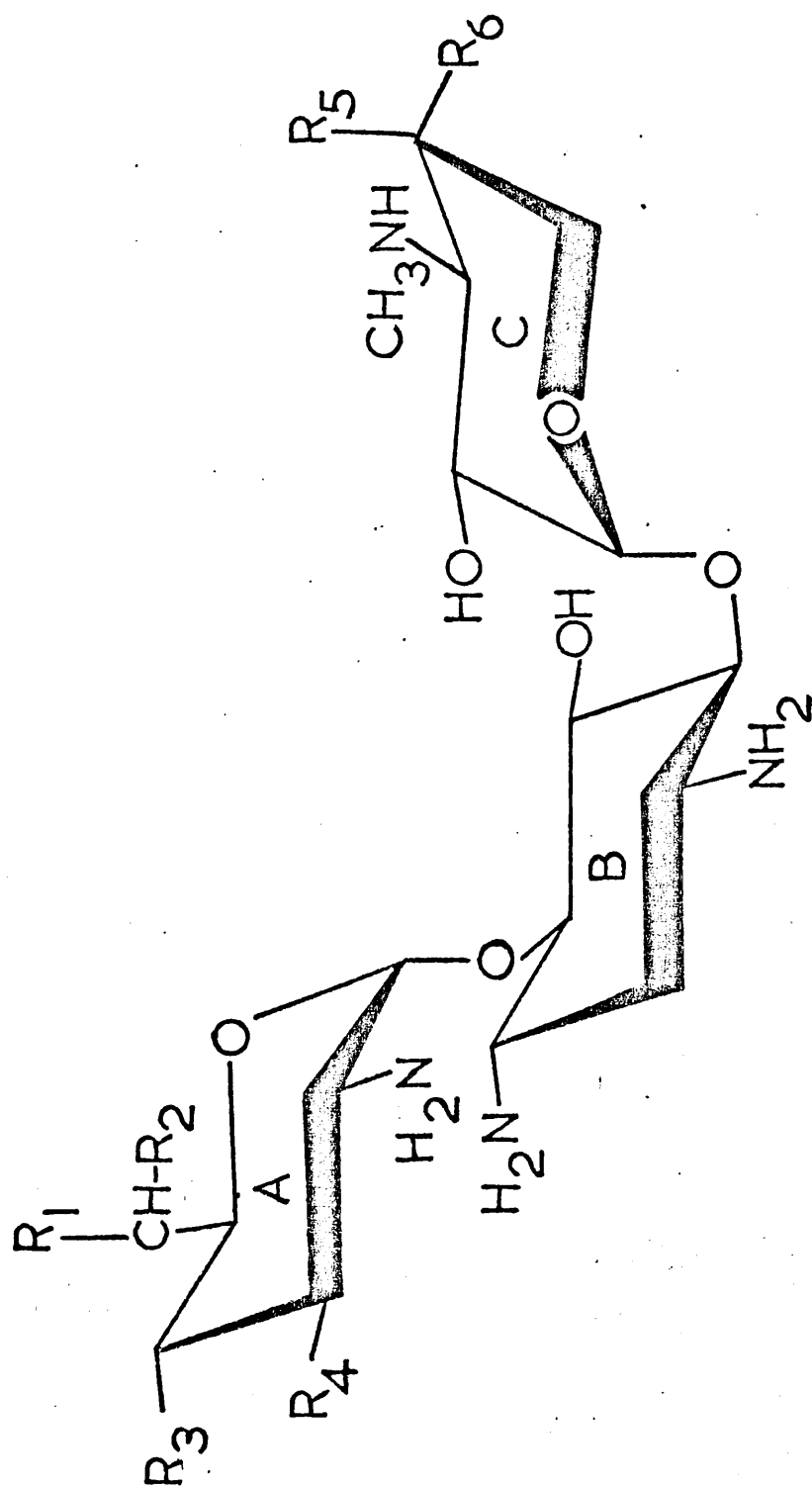
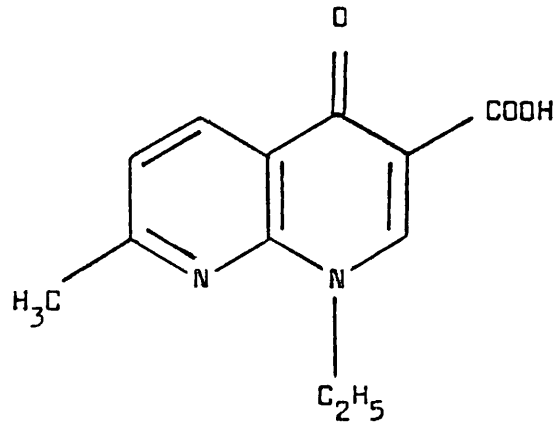
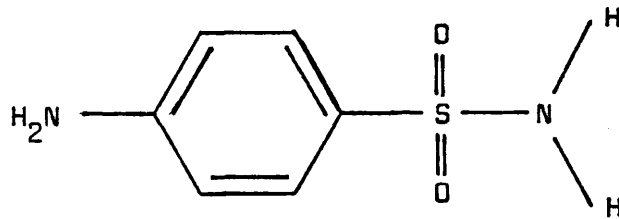
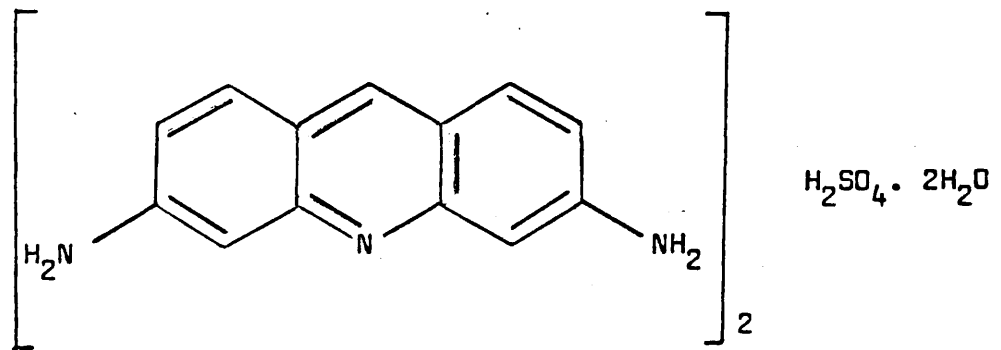

Figure 1.9

The structure of nalidixic acid,
sulphanilamide and proflavine

Nalidixic acidSulphanilamideProflavine

nalidixic acid specifically arrests the later stages of chromosomal replication in sensitive organisms, suggesting that the drug causes newly synthesised single stranded DNA precursors to be metabolically unstable. This transience of the newly synthesised DNA intermediates thus causes net DNA synthesis to cease.

Proflavine (3,6-diaminoacridine hemisulphate) is an antibacterial dye of the acridine family (Figure 1.9). The acridine dyes are known to bind strongly to DNA molecules and Lerman (1961) suggested that proflavine molecules are intercalated between layers of base pairs within the DNA molecules. Acridines also inhibit DNA synthesis in sensitive bacterial cells. Evidence thus suggests that proflavine and related drugs have DNA molecules as their site of action. However, the effects of other binding sites (such as the cytoplasmic membrane) on the degree of inhibition of these drugs has yet to be fully investigated experimentally (Hugo, 1971).

The mechanism of action of the sulphonamide drugs (Figure 1.9) is to inhibit folic acid formation from p-aminobenzoic acid and dihydropteridine. Most sulphonamides have a higher affinity for the tetra-hydroptericoic acid synthetase than does the normal substrate p-aminobenzoic acid, and in the presence of equimolar quantities of the two compounds, folic acid biosynthesis in the cells is impaired (Hotchkiss and Evans, 1960; Ortiz, 1970). It is believed that the mechanism of action of the drugs is not simply a direct steric competition at the active centre of the enzyme. The sulphonamide either replaces the p-aminobenzoic acid as substrate resulting in folate analogues or as suggested by Seydel (1968), the pteridine alcohol which acts as the starting point of the

synthesis exists in tautomeric equilibrium with the corresponding aldehyde and this will form a Schiff base with the sulphonamide. In either case pteridine will be removed and will thus not be available for folate synthesis.

1.5 Resistance to Antibiotics and Antibacterial Agents

The use of a new antibiotic or antibacterial agent in the treatment of bacterial infections eventually leads to the appearance of resistant strains. Drug resistance mechanisms may be broadly divided into two classes: (a) some cellular component becomes altered in such a way that the antibacterial agent does not reach or does not interact with its normal target site within the cell, and (b) the antibiotic itself becomes chemically modified and thus inactivated. Gale et al, (1972) have defined four mechanisms of antibiotic resistance:

- (a) the cellular target is altered;
- (b) there is a reduction in the physiological importance of the target;
- (c) an exclusion mechanism prevents the drug from reaching its target;
- (d) drug degrading enzymes are produced.

(a) Target alteration

As an example of this type of resistance, Nomura (1970) has reported that a mutation of the 30S ribosome subunit in bacteria causes resistance to the aminoglycoside antibiotic streptomycin,

the mutation resulting in the antibiotic not being bound to the ribosomes of resistant mutants.

(b) Reduction in the physiological importance of the target site

Resistance of this type may be induced by growing cells of P. aeruginosa in magnesium-depleted medium (Brown and Melling, 1969a,b); this causes the cells to become more resistant to both polymixin-B and EDTA. Cells grown normally in magnesium-sufficient media would be susceptible to lysis by these agents.

The generally higher level of resistance to anti-peptidoglycan drugs in Gram-negative, as compared to Gram-positive bacteria, may be due to the cell wall of the former being a modified version of the cell wall of the latter, having less dependence on peptidoglycan for cell wall stability.

(c) Drug exclusion

A number of reports have implicated exclusion mechanisms of resistance in Gram-negative cells and especially in cells of P. aeruginosa. For example, Hamilton (1970) suggested that in P. aeruginosa among other bacteria, the cell wall acts as a barrier to membrane active agents. Few and Schulman (1953) and Newton (1956) have indicated that there is a relationship between uptake and sensitivity to polymixin for several species, again including P. aeruginosa.

Changes in surface lipid have also been associated with antibiotic resistance. Pechey et al (1974) found a relationship between surface lipid and gentamicin-resistance in P. aeruginosa. For the same species Ivanov et al (1964) extracted cells with petroleum ether (allegedly without altering viability) and found

that their sensitivity to a number of antibacterial agents increased.

(d) Antibiotic modifying enzymes

This type of resistance is normally associated with an extrachromosomal element or plasmid which determines the synthesis of the enzymes. These plasmids or R-factors are of clinical importance because they can be transferred during conjugation among a wide variety of bacterial species, between pathogenic and non-pathogenic strains, thus increasing the spread of resistance.

The mechanism of enzymatic resistance to the penicillin-type drugs has been carefully studied in both Gram-negative and Gram-positive bacteria and has been found to be due to the production of a β -lactamase (penicillinase) which hydrolyses the β -lactam ring present in the penicillin and cephalosporin antibiotics (Figure 1.7). The β -lactamases produced by Gram-negative bacteria are cell-bound, unlike those in the Gram-positive bacteria which are excreted into the surrounding medium (Neu and Winshell, 1972). Not all β -lactamases are determined by plasmids. Chromosomally mediated resistance to β -lactam antibiotics has been reported (Lindström et al, 1970).

R-factor mediated resistance to the aminoglycoside group of antibiotics has also been extensively studied. Three different mechanisms are now known by which these antibiotics can be enzymatically inactivated:

- (i) acetylation of amino groups;
- (ii) adenylation of hydroxyl groups;
- (iii) phosphorylation of hydroxyl groups.

These enzymes act on the antibiotic molecules by substituting key residues. The acetylating enzymes use acetyl coenzyme A as the

source of acetyl groups for this purpose, whilst the adenyating and phosphorylating enzymes both use ATP, the former as a source of adeny1 groups and the latter as a source of phosphate groups.

As an example of this type of resistance, Mitsuhashi et al (1971), Jacoby (1974) and Bryan et al (1974) have reported the occurrence of gentamicin-acetylating enzymes in strains of P. aeruginosa, whilst Brzezinska et al (1972) have reported that such gentamicin-inactivation occurs by acetylation at the 3-amino group of the 2-deoxystreptamine ring (Figure 1.8) in the gentamicin C antibiotic; gentamicin A is a poor substrate for acetylation.

1.6 Microcalorimetry

Microcalorimetry is the measurement and study of small heat changes, though not necessarily involving small quantities of material. The production of heat is an obvious change which occurs during microbial metabolic activity, and this observation led to attempts at calorimetric measurements early in the development of microbiology. Calorimeters were first used scientifically at the end of the eighteenth century, often for investigations on life processes. For example, Crawford, Laplace and Lavoisier measured the heat quantities produced by animal respiration as early as 1780. Dubrunfaut (1856) applied calorimetry to microbiology, studying the heat production during alcoholic fermentation by measuring the considerable temperature rise in a large (21,000 litre) quantity of material contained in a vat. This work was repeated by Bouffard

(1895) on a much smaller scale, and by making appropriate corrections, he obtained an accurate value for the enthalpy change involved in the fermentation of glucose to alcohol. Other microcalorimetric studies followed this, usually adopting a qualitative approach, although these researches were hindered by the limitations of their apparatus and frequently by the inadequate definition of experimental conditions. However, modern calorimetric apparatus has now reached a stage of development where it has become a promising research tool in many areas of biochemistry, microbiology, biology etc.. In microbiology it has been shown that thermogenesis in microbial cultures is both reproducible and characteristic of a given individual organism and medium (Prat, 1963). The factors affecting the heat-producing behaviour of micro-organisms have been studied in some detail and these factors are known to vary at different phases during the growth cycle.

Chemical processes are accompanied by the liberation or absorption of energy as heat. This is because different substances have differing amounts of energy and thus after a reaction, the total energy of the products differs from the total energy of the reactants, this difference giving rise to the heat change. The energy difference is dependent only on the initial and final states of the system (where system refers to a defined amount of matter containing fixed quantities of given substances) and is independent of the complexity or simplicity of the pathway of the reaction. This is known as the Law of Hess and it is such changes that are measured in calorimetry.

Chemical reactions in biological systems may be considered to occur in solution at constant pressure and volume. Under these

conditions thermodynamic differences of definition between enthalpy and energy can be ignored and thus the energy change which accompanies a reaction becomes the change in enthalpy or ΔH , heat of reaction. The calorimetrically measured heat evolution, Q , is thus correlated with the heat of reaction, ΔH , for a reaction in an isolated system in which no external work is done. Hence for a given reaction:

$$Q = -n\Delta H$$

i.e. the quantity of heat evolved depends on the number (n) of moles of reaction which have taken place. ΔH is negative for an exothermic reaction where a decrease of energy has occurred.

It follows that when more than one reaction occurs at the same time, the total heat, Q , is the sum of the individual processes. This situation obtains in calorimetric experiments; a series of simultaneous reactions occurring in a closed system with energy unable to pass from that system. Thus what is detected in such experiments with micro-organisms is the total energy change occurring over any given period of time, within the system, making the technique an extremely general one, even though it can be very sensitive to small heat changes.

In spite of the non-specific nature of the technique, it has often been found that in experiments with living organisms, a few simple reactions tend to predominate and are thus detected in records of heat production. Results obtained with micro-organisms have tended to indicate that almost all heat production detected during metabolism is caused by catabolic processes, whilst anabolism has a comparatively small effect (Morowitz, 1960; Boivinnet, 1964; Senez and Belaich, 1965).

The non-specific nature of microcalorimetry makes it necessary that supplementary data such as pH changes, bacterial dry mass etc. should be obtained at the same time as the calorimetric results. This non-specificity may be an advantage in complex biological systems, where an unknown phenomenon may be revealed, which would not have been shown by a more specific technique.

Another advantage of calorimetry is that it is the sample itself which provides the signal (heat output) which is to be recorded, without any necessity to add reagents etc. Furthermore, the studies are made on intact, living cells maintained under optimum conditions.

1.7 Types of Calorimeter

There are two main categories of calorimeter in use:

(a) adiabatic calorimeters and (b) heat conduction calorimeters.

Both types can be used for microbiological work.

(a) Adiabatic calorimeters

In the ideal adiabatic calorimeter the reaction vessel is as isolated as possible from its environment, so that there is no heat exchange between the calorimeter and environment. This results in the greatest possible temperature rise in the reaction vessel and with this type of calorimeter it is the temperature change which is measured. Electrical heating may be applied to an identical balance vessel, causing it to maintain the same temperature as the reaction vessel. A feedback control circuit is thus necessary to

ensure that balance is maintained between the two vessels. In such a case, temperature is not measured directly, but the electrical energy necessary to maintain balance is continuously recorded.

(b) Heat conduction calorimeters

With an ideal heat conduction (heat flow) calorimeter, instead of the reaction vessel being isolated, the heat evolved is allowed to flow along a controlled path to a heat sink. The temperature in the reaction vessel thus tends to remain constant. The rate of passage of heat is detected by measuring the temperature gradient along the path. A multijunction thermopile is used for this measurement in these calorimeters; the thermopile is the path through which heat must pass from the reaction vessel to the heat sink.

In the current study a heat conduction type calorimeter was used, and this was fitted with different cells for different experiments; a flow system was used for studies on bacterial growth and a batch system for studies on bacterial surface/antibiotic interactions.

The flow system employed (Monk and Wadsö, 1968) differs from most heat-conduction instruments in which the reactants are isolated and contained in the microcalorimeter cell. In the flow system the reaction mixture (in this case the growing bacterial culture) is pumped into the calorimeter cell, passing through heat-exchange coils before entering the cell so that thermal equilibrium is maintained. Heat produced in the cell by the bacteria causes a temperature difference and thus heat flow between the cell and the heat sink (which because of its relatively high heat capacity absorbs the heat flow). The thermopile located between the cell

and the heat sink measures the temperature difference (proportional to heat flow) as an electrical voltage. The voltage is then amplified and recorded as heat liberated (or absorbed) per unit time.

The twin cell principle is employed to cancel external disturbances; the thermopiles of the reaction cell are connected in opposition to the thermopiles of an identical cell which is not used during the experiment.

The twin cells and heat sink are contained in a thermostatic air bath (Figure 1.10), which makes it possible to maintain a suitable, constant environmental temperature for the reaction. Before an experiment can begin, the calorimeter must be in equilibrium so that each part of the heat sink is at the same temperature as the surrounding air bath, the temperature controller and sensor maintaining constant temperature.

A main advantage of flow calorimetry is that as the reaction vessel is outside the calorimeter, sampling or the addition of reagents or nutrients to the growing culture can be performed without disturbing the calorimetric record. A disadvantage is that a period of some 15 minutes elapses between a cell leaving the reaction vessel and reaching the calorimeter cell. This may mean that there is some slight difference in the stage of growth of bacteria in the growth vessel and the calorimeter cell. To help overcome depletion of oxygen during this time, the culture may be aerated during its passage to the calorimeter cell. Another possible source of error is that wall growth of bacteria in the reaction cell may occur during prolonged cultivation.

Figure 1.10

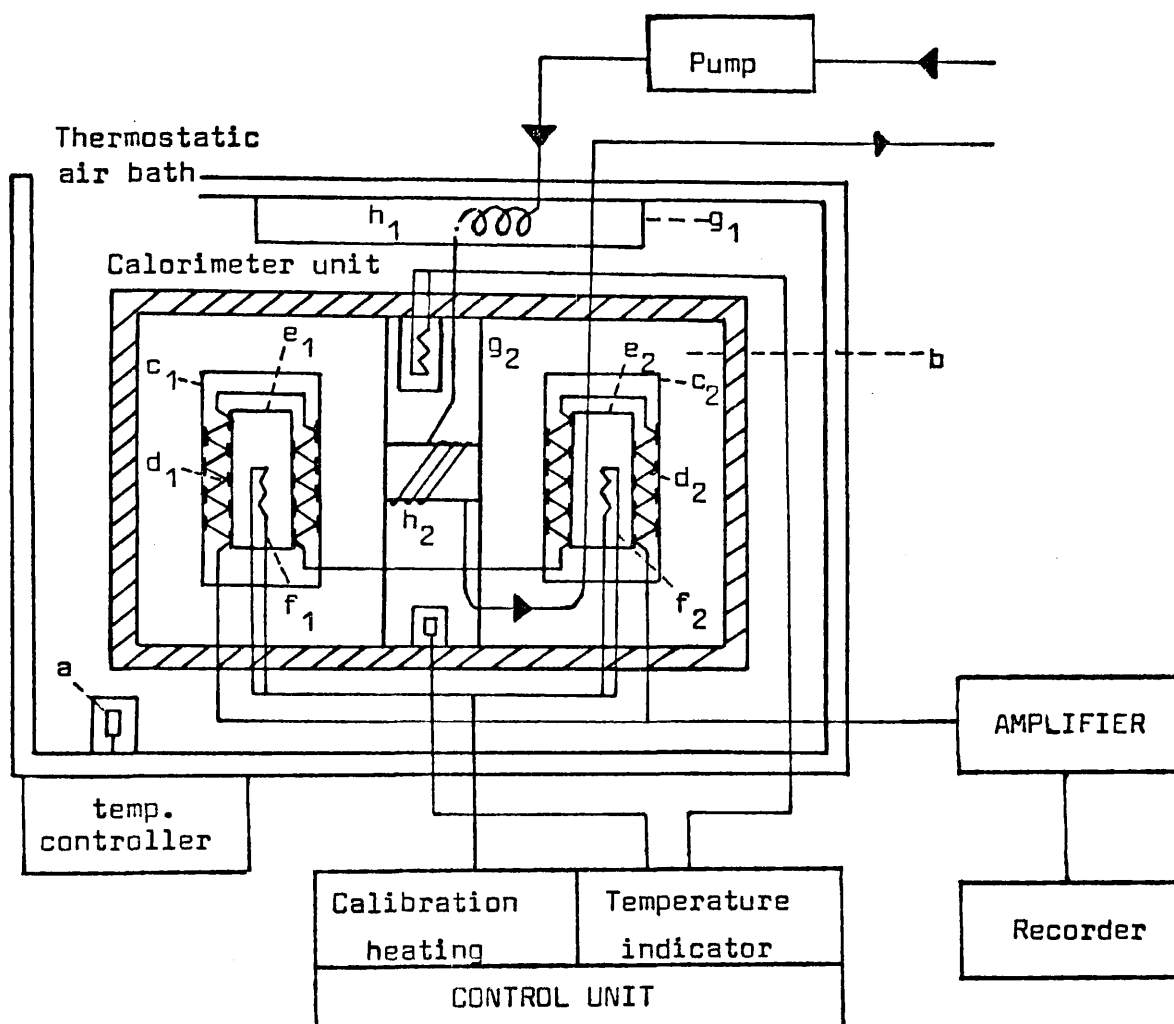
The flow-through calorimeter

a = temperature sensor

b = heat sink

c_1, c_2 = detectors

d_1, d_2 = thermopiles

e_1 = reference cell

e_2 = flow-through cell

f_1, f_2 = calibration heater

h_1, h_2 = heat exchange coils

g_1, g_2 = heat exchangers

To examine possible bacterial surface/gentamicin reactions, the flow cell was replaced by the batch cell. In these experiments each compartment of the reaction cell is filled with one of the reactant solutions and when temperature equilibrium has been reached the cell is automatically rotated, thus causing the reactants to be mixed. Any heat evolved or absorbed is detected by thermopiles as before and the twin cell principle is again employed.

For both batch and flow experiments a calibration heat pulse is produced by passing an electric current to the calibration heater, whilst both cells contain non-reacting solution (or non-viable bacterial suspension). Electrical energy is used for this purpose since electrical quantities can be measured and timed with high precision and are easily and rapidly produced.

1.8 Objects of the Investigation

The objects of this investigation were:

- (a) to make a microcalorimetric study of cells of K.aerogenes during growth both in the presence and absence of antibiotics or antibacterial agents; in this way it was hoped to obtain further information on the mode of action of the antibacterial agents;
- (b) to use the information gained from (a) to make a preliminary microcalorimetric study of cells of strains of P.aeruginosa growing in the presence and absence of gentamicin;

- (c) to make an analysis of cell components of strains of P. aeruginosa in an attempt to correlate possible differences between strains with differences in levels of resistance to gentamicin.

CHAPTER 2

EXPERIMENTAL TECHNIQUES

2.1 BACTERIOLOGICAL TECHNIQUES

2.1.(a) Strains

The strains of K. aerogenes and P. aeruginosa used in this study and their sources are listed in Table 2.1.

The strains of P. aeruginosa were grown overnight on nutrient agar slopes in loosely capped universal bottles at 37 °C and stored at 5 °C. The strains were routinely maintained by bimonthly subculturing onto fresh agar slopes. When strains were in frequent use they were subcultured more often.

The strain of K. aerogenes was grown overnight in nutrient broth in a loosely capped 100 cm³ screw top medical flat at 37 °C and stored at 5 °C, with routine subculturing as above.

When required for microcalorimetry, strains of P. aeruginosa and K.aerogenes were similarly maintained in pure synthetic medium.

2.1.(b) Media

A synthetic medium was made up as follows, using Analar grade chemicals:- Potassium dihydrogen ortho-phosphate 4.5 g

Ammonium sulphate 1.25 g

Magnesium sulphate (7H₂O) 0.05 g

These were dissolved in glass distilled water and made up to 1 dm³, sodium hydroxide being added to give a pH value of 7.0. This solution was then autoclaved in 480 cm³ volumes in 1 dm³ conical flasks; when required for use 120 cm³ of sterile 1% (w/v) glucose solution was added.

Table 2.1

Bacterial strains

Strain	Source
<u>K. aerogenes</u>	
NCTC 418	NCTC
<u>P. aeruginosa</u>	
1	Mr. J.T. Magee, Nicholas International Ltd., 225, Bath Rd, Slough, Berks.
1A/20	Strain 1
100	Dr. E. Schoutens, Brugmann Hospital, Institut Pasteur du Brabant, Bruxelles, Belgium.
104	Mr. Slocombe, Beecham Research Laboratories, Brockham Park, Betchworth, Surrey.
107	Same as strain 1.
Capetown no. 18	Dr. G.A. Jacoby, Massachusetts General Hospital, Boston, Massachusetts 02114.

Nutrient broth was prepared by adding 13 g of Oxoid Nutrient Broth (code CM1) powder to 1 dm³ distilled water contained in a 2 dm³ conical flask. The flask was then plugged with cotton wool and sterilised by autoclaving.

Nutrient agar was prepared by adding 25 g of powdered Oxoid Nutrient Broth No. 2 to 1 dm³ of distilled water followed by Oxoid Agar No.1 to give 1% w/v agar. The solution was distributed into about 350 cm³ lots into 500 cm³ screw top bottles and sterilised by autoclaving. Agar slopes were prepared by melting this stock agar in an autoclave and aseptically pipetting 10 cm³ portions into sterile 25 cm³ universal bottles or 100 cm³ into 500 cm³ screw top medical flats. The bottles were then sloped before the agar solidified.

Agar plates containing gentamicin were prepared by adding the appropriate weight of gentamicin to a known volume of melted agar. The agar was then re-sterilised by autoclaving and 10 cm³ portions were pipetted aseptically into petri dishes.

2.1.(c) Growth of strains for experimental purposes

Agar slopes were inoculated from an initial starter culture using a sterile platinum loop and incubated for 18 h at 37 °C. Agar plates used in 'training' of bacteria to gentamicin were also inoculated using a sterile platinum loop.

For nutrient broth cultures grown in 1 dm³ volumes, a starter culture was first grown by inoculating 20 cm³ of nutrient broth contained in a 100 cm³ screw top bottle from an agar slope using a sterile platinum loop. After overnight incubation at 37 °C

10 cm³ of this culture was used to inoculate 1 dm³ of nutrient broth contained in a 2 dm³ conical flask. The culture was then stirred with a magnetic stirrer and incubated at 37 °C for 18 h.

Nutrient broth cultures were also grown in 50 cm³ volumes in 100 cm³ screw top medical bottles. These were inoculated from overnight starter cultures using a sterile platinum loop and the bottles loosely capped and sloped. These were then incubated at 37 °C for 18 h.

Cultures in synthetic media were grown in 600 cm³ batches. Starter cultures were first grown by inoculating 30 cm³ of synthetic medium contained in a 100 cm³ screw top bottle, with cells from an agar slope using a sterile platinum loop. After overnight incubation at 37 °C with aeration, the whole of this culture (i.e. 30 cm³) was used to inoculate 600 cm³ of synthetic medium contained in a 1 dm³ conical flask. The culture medium, incubated in a water bath at 37 °C, was then stirred with a magnetic stirrer and well aerated (1 dm³ min⁻¹).

2.1.(d) Growth of cells during training to antibiotics and antibacterial agents

Cells of P.aeruginosa strain 1 were trained, using the method of Rolinson et al (1960), to develop resistance to gentamicin, i.e. to enable them to grow in the presence of 20 µg cm⁻³ of the antibiotic in nutrient agar.

Cells of strain 1 were grown initially at 37 °C on nutrient agar containing gentamicin at half the minimum inhibitory

concentration (MIC). At first, growth was sparse and slow. Using this growth to inoculate the next generation at the same gentamicin concentration, larger and more vigorously growing colonies were obtained. These final colonies were then used to inoculate a plate containing a concentration of gentamicin double that previously used. By repeating this procedure in stepwise fashion, each time doubling the concentration of antibiotic, copious growth was finally obtained on nutrient agar containing $20 \mu\text{g cm}^{-3}$ of gentamicin. The strain was then designated 1A/20 and was maintained on nutrient agar slopes in the presence of the same concentration of gentamicin.

Cells of K. aerogenes were 'trained' to grow in the presence of various antibiotics and antibacterial agents using a technique similar to that described above. The cells were grown (with aeration) in 25 cm^3 volumes of synthetic medium containing various concentrations of the antibacterial agents. Sub-culturing was repeated at each concentration of each agent as before, until vigorous growth was obtained. The cells were trained to grow well at the following concentrations:

penicillin	$400 \mu\text{g cm}^{-3}$
gentamicin	$0.2 \mu\text{g cm}^{-3}$
proflavine	$100 \mu\text{g cm}^{-3}$
sulphanilamide	$1200 \mu\text{g cm}^{-3}$

2.1.(e) Measurement of MIC of antibiotics and antibacterial agents

The minimum inhibitory concentration, MIC, of an antibiotic is the lowest concentration of antibiotic required to prevent growth.

This was measured by the method described by Gould (1960).

A series of metal capped test tubes containing a range of concentrations of antibacterial agent in 5 cm³ of nutrient broth or synthetic medium, was prepared by two times serial dilution. As a control, a drug-free medium was used. When gentamicin was used in nutrient broth, these tubes were then sterilised by autoclaving. When synthetic medium or heat-labile drugs were used, the antibacterial agent was weighed out aseptically and added to sterile medium to give a stock solution, which was then subsequently diluted under aseptic conditions.

Each tube was then inoculated with approximately 10⁵ bacteria from an 18 h culture and the tubes incubated for 48 h at 37 °C. At the end of this time the lowest concentration of antibacterial agent in which no turbidity (i.e. no growth) was observed, was recorded as the MIC.

2.1.(f) Cleaning and sterilisation of apparatus

Glassware was washed and scrubbed in tap water, rinsed twice in distilled water and then dried overnight in an oven at 110 °C.

All glassware, solutions and growth media which were required to be sterile, were autoclaved at 15 lb in⁻² for 30 minutes. Before autoclaving, pipettes and Pasteur pipettes were plugged with cotton wool and placed in metal cannisters. Contaminated glassware was autoclaved before washing. Contaminated pipettes were soaked in 10% Milton solution before being autoclaved and washed. Contaminated disposable apparatus was immersed in 1% lysol solution before disposal.

2.2 MICROCALORIMETRY

Flow-cell microcalorimetry was used to follow heat changes accompanying bacterial growth and batch-cell microcalorimetry was used to detect the extent of interactions between bacterial cells and antibiotic.

2.2.(a) Flow-cell microcalorimetry

(i) Growth of bacteria for flow-cell microcalorimetry

Cultures were grown in 600 cm³ batches of synthetic media using overnight starter cultures for inoculation (Section 2.1.(c)). Cells of strains of K. aerogenes and P. aeruginosa were grown both in drug-free medium and in the presence of different concentrations of different antibiotics or antibacterial agents. During growth, the culture was continuously sampled for examination in the microcalorimeter cell.

(ii) Measurement of heat output during bacterial growth

The thermograms accompanying growth of cells of K. aerogenes and P. aeruginosa in pure synthetic medium or in synthetic medium containing different concentrations of antibiotics at 37 °C were obtained using an LKB 10700-1 flow microcalorimeter. The experimental arrangement was similar to that used by Eriksson and Wadsö (1971), and is shown as a flow chart in Figure 2.1.

The growing bacterial culture was pumped from the culture vessel using an LKB 10200 peristaltic pump. The culture reached a Y-piece soon after leaving the culture vessel where it was mixed with

Figure 2.1

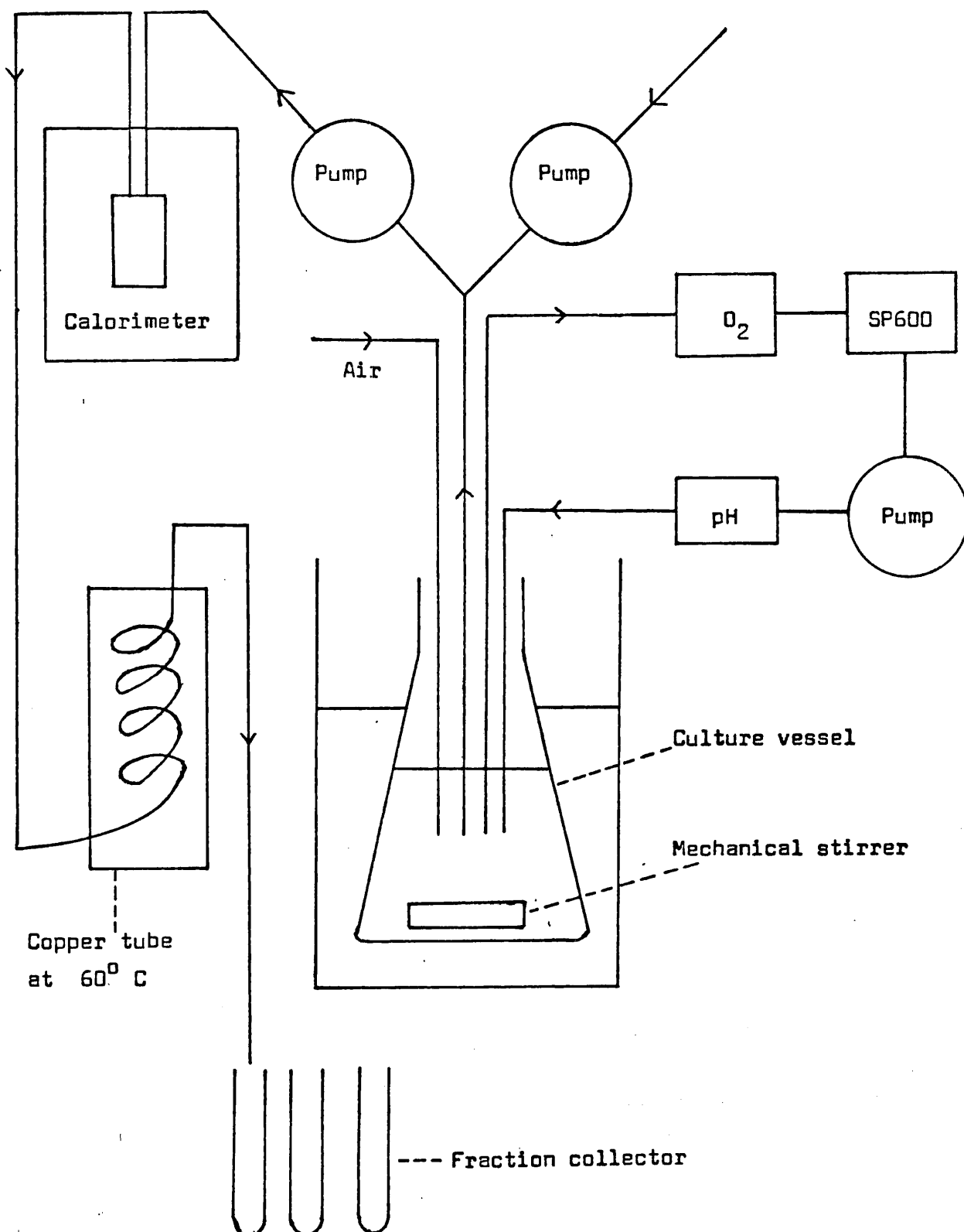
Flow chart of experimental arrangement

a steady flow of air, of approximately equal volume, pumped from a second peristaltic pump. This aeration, soon after leaving the culture vessel, reduced the oxygen depletion in the microcalorimeter.

The culture/air mixture was then passed into the calorimeter which was fitted with an aerobic steel cell (Figure 2.2). This cell eliminated the thermal fluctuations associated with the passage of air bubbles through a conventional flow-cell (Monk and Wadsö, 1968). The cell held a sample volume of 1.2 cm^3 and at a liquid pump rate of $6-9 \text{ cm}^3 \text{ h}^{-1}$, about 15 minutes were needed to pump the growing culture to the calorimeter and fill the cell. Since the bacteria in the connecting tubing and in the calorimeter cell had the necessary requirements for growth, it was assumed that at any given time the difference between the stage of bacterial growth attained in the cell and in the culture vessel was small. The possibility of oxygen depletion in the tube was considered, but estimation of oxygen tension immediately before or after the microcalorimeter cell presented great difficulties.

The microcalorimeter reaction cell is contained in a heat sink, which is in turn located inside a thermostated air bath, this arrangement providing a constant temperature environment. The temperature used for all experiments was 37°C . Heat liberated or absorbed by the growing bacterial culture passing through the cell caused temperature differences and corresponding heat flow between the cell and the heat sink. These temperature differences (which were proportional to the heat flow) were measured as electrical voltage by thermopiles located between the cell and the heat sink. The voltage differences were then amplified by an amplifier and

Figure 2.2

The steel aerobic cell

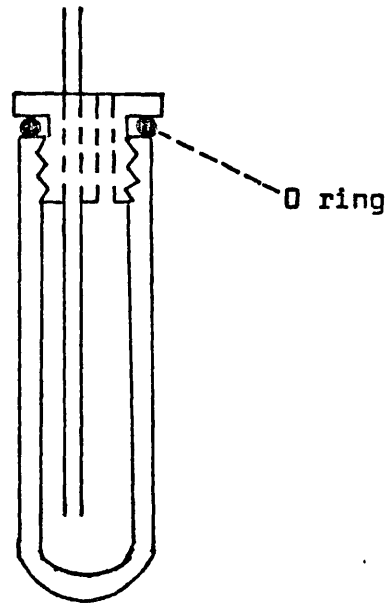

The batch cell

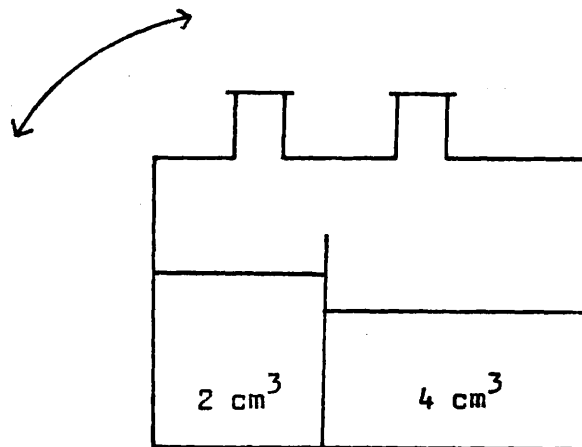

presented on a recorder as base line shifts (i.e. heat absorbed or liberated) per unit time. To cancel external disturbances, the thermopiles of the reaction cell are connected in opposition to the thermopiles of a second reaction reference cell, also contained in the heat sink, which was not used during the experiment. For thermal detection of bacterial growth, the microcalorimeter was operated over the sensitivity range of 0-100 mV.

To convert the electrical voltage output into a heat output expressed as either W or $J s^{-1}$, calibration using a known measured heat impulse was necessary. At the end of a growth experiment the cells were killed by the addition of formalin; when these cells were pumped through the microcalorimeter cell there was no heat response. An internal current of 2.0 to 3.5 mA was then applied for 30 minutes to a resistance ($\sim 50 \Omega$) located in the cell block; this produced an evolution of a known amount of heat. From the trace, the conversion factor was calculated. The calibration was made for each experiment at first, but since it was so reproducible and constant, it was unnecessary to repeat for each subsequent experiment. Frequent checks were made.

Thin ^{poly-}propylene tubing of internal diameter 0.2 cm was used to make all the connections between the culture vessel and the aerobic cell, pH electrodes, oxygen electrodes etc.. This was sterilised before each run by pumping a 70% ethanol/water mixture and then sterile distilled water through the system for about 2 h. The appropriate ends of the tubing were then aseptically transferred into the culture vessel containing sterile medium (thermostatted at 37 °C). Aeration of the medium was commenced and the medium and alternate

segments of air were pumped through the microcalorimeter cell to give a steady baseline reading on the recorder. This stable baseline was maintained for about an hour and the medium was then inoculated, usually using about 30 cm^3 of an 18 h culture. The heat output was recorded using an Oxford 3000-series recorder running at 10 cm h^{-1} . After the culture had passed through the microcalorimeter, it was passed up through a heated copper coil (maintained at $\sim 60^\circ \text{C}$) to kill the organisms. The dead culture was then collected in boiling tubes on a fraction collector (a sample was collected every 30-40 minutes). These samples were used for the assay of either substrates e.g. glucose, or intermediates e.g. pyruvate, lactate etc..

(iii) Measurement of oxygen tension, biomass and pH during growth

The oxygen tension, absorbance and pH of the culture were recorded by re-circulating the culture at $400 \text{ cm}^3 \text{ h}^{-1}$ through an EIL 1521 oxygen electrode, a 1 cm path length flow cuvette (in a Unicam SP 600 spectrophotometer set at a wavelength of 625 nm) and a micro-combination EIL 1140 200 pH electrode (Figure 2.1). The oxygen and pH electrodes were both sleeved in such a way that only a small volume of sample surrounded the electrodes. This was especially important for oxygen measurements, where the small sample volume and the high rate of pumping combined to minimize errors caused by oxygen depletion across the membrane. The oxygen electrode was calibrated by first soaking it in a 5% w/v solution of sodium sulphite to give the zero reading and then passing water saturated with air through the flow system at the experimental pump rate and adjusting the

reading to give a 100% value (i.e. 156 mm Hg). Growth of bacteria was followed by the increase in absorbance readings of the suspension at 625 nm. Oxygen tension and pH were simultaneously recorded against time by an Oxford 3000-series two-pen recorder and the absorbance and thermogram by a second recorder. The chart speed on each recorder was 10 cm h^{-1} . Direct comparison of heat output, oxygen tension, pH and biomass was immediately possible. Calibration curves of bacterial dry weight (mg cm^{-3}) against absorbance were constructed in separate experiments using suspensions of washed 18 h cells of K. aerogenes and P. aeruginosa strain 1 (Section 2.3.(b).(ii)).

(iv) Determination of glucose content in the medium

Glucose analysis was carried out on clear extracellular fluid obtained by centrifugation of samples of bacterial suspension from the calorimeter.

The technique used (Dubowski, 1962) was based on the formation of a coloured compound between glucose and o-toluidine. 3 cm^3 of a 6% v/v solution of freshly distilled o-toluidine in glacial acetic acid was added to 1 cm^3 of a standard glucose solution or of suitably diluted extracellular fluid. The mixture was boiled in a water bath for 15 minutes. After cooling the solution, the absorbance was measured at 630 nm in a cuvette of path length 1 cm against a similarly treated reagent blank in which the sample was replaced by distilled water. The absorbance was then compared with a standard curve to give the glucose concentration in the range $0-0.3 \text{ mg cm}^{-3}$. The standard curve was established for each series of analyses, since oxidation

of the reagent caused darkening with age. The o-toluidine method was used in this work in preference to a specific enzyme system because of its simplicity and speed. The use of glucose oxidase (Washko and Rice, 1961) in the form of the Worthington 'glucostat' kit necessitated the adjustment of each sample to a neutral pH.

2.2.(b) Batch-cell microcalorimetry

An LKB 10700-2 batch microcalorimeter was used to detect heat changes occurring as a result of interaction between gentamicin and cells of either K. aerogenes or P. aeruginosa.

In these experiments gentamicin solutions were made up in distilled water or synthetic medium, whilst bacterial suspensions were centrifuged, washed three times with distilled water and finally suspended in distilled water or synthetic medium. Cells of strains of P. aeruginosa were suspended in synthetic medium, whilst cells of K. aerogenes were suspended in distilled water (because the absence of a lag phase makes it impossible to obtain a steady baseline before the reaction was started).

The two reaction cells of the batch calorimeter are contained in the aluminum heat sink, which is in turn surrounded by styrofoam and located in the rotatable calorimeter unit. Each reaction cell (Figure 2.2) consists of a glass chamber, divided for part of its height into two compartments by a barrier. The reacting solutions previously thermostatted at 37 °C were put in either side of one of the cells (1.5 cm³ gentamicin solution and 3 cm³ bacterial suspension respectively). The other cell which acted as a reference cell was

similarly filled with the same amounts of distilled water in each side.

After thermal equilibrium had been obtained, as shown by the constancy of the baseline for a period of about half an hour, the reactants were mixed. The mixing button on the control unit was depressed to make the calorimeter unit rotate. The resulting absorption or liberation of heat was detected by thermopiles as in the flow calorimeter, and the voltage difference amplified (the sensitivity settings varied between 0-30 μ V and 0-1 mV) and presented as a trace on a recorder chart. The area of the curve above the baseline is a measure of the heat of reaction. The heat of dilution of the bacterial suspensions and gentamicin solutions with water (for K. aerogenes) or pure medium (for P. aeruginosa) were determined by repeating the mixing process, i.e. bacterial suspensions with water or medium and gentamicin solutions with water or medium, and subtracting the areas of the resulting curves from the complete reaction curve. This gave the heat of reaction between gentamicin and bacterial cells.

The calibration constant was obtained after each experiment. The reactants and water blanks were left in the cells and the calorimeter unit again rotated and at the same time a known current (2-5 mA) was passed through the calibration heater located in the reactant cell. The duration of the current (2-30 seconds) was chosen so that the area of the calibration curve was as close as possible to the area of the experimental curve. This enabled the area of the curve to be converted into a total heat output measured in joules.

To increase the accuracy of the measurements, correction runs were made to determine the differential heat of friction between

the two cells during the reaction and calibration runs. This was achieved by further rotation of the calorimeter unit, after the reactants had been mixed. Under these conditions, no further heat of reaction is liberated or absorbed. The areas of the resulting curves were then subtracted from the areas of the experimental and calibration runs (in most cases the same sensitivity setting was used).

After each mixing procedure was complete, the glass cells in the microcalorimeter were well washed with distilled water, sterilised with ethanol, rinsed again with distilled water, and thoroughly dried with an air suction pump.

2.3 CHEMICAL ANALYSIS OF WHOLE BACTERIAL CELLS

2.3.(a) Growth and preparation of cells for analysis

(i) Growth and preparation of cells for lipid and amino-acid analysis: cells of P. aeruginosa strains 1, 100, 104, 107 and 1A/20 were grown in 1 dm³ batches of nutrient broth for 18 h at 37 °C. The cultures were then centrifuged and the cells washed three times with distilled water.

(ii) Growth and preparation of cells for protein, nucleic acid and polysaccharide analysis: cells of P. aeruginosa strains 1, 100, 104, 107 and 1A/20 were grown in 50 cm³ batches of nutrient broth for 18 h at 37 °C. The cultures were then centrifuged and the cells washed four times with saline solution (0.15 mol dm⁻³) and finally suspended in saline.

2.3.(b) Determination of bacterial dry weight

(i) For lipid and amino-acid analysis: after washing, the bacterial cells were dried to constant weight in a vacuum desiccator over P_2O_5 . The dried cells were then powdered and weighed before use.

(ii) For protein, nucleic acid and polysaccharide analysis: a standard curve was produced using cells of P. aeruginosa strain 107. A culture of this strain grown for 18 h at $37^\circ C$ was centrifuged, the cells washed four times with saline and finally suspended in saline to give an absorbance of about 0.5 at 625 nm against a saline blank using an S.P. 600 spectrophotometer. Samples of this suspension were then diluted with saline to give a range of different concentrations down to 1/8 th of the original and the absorbance of each suspension recorded. 15 cm^3 samples of the original suspension and of the saline (for NaCl correction) were pipetted into accurately weighed 25 cm^3 beakers, placed in an oven and dried to constant weight at $100-105^\circ C$. A standard curve of dry weight against absorbance was then plotted (Figure 2.3), and hence the dry weight/mg cm^{-3} of any suspension was determined from its absorbance.

The same technique was used to produce standard curves for the determination of the bacterial dry weight/mg cm^{-3} of cultures of K. aerogenes and P. aeruginosa grown in synthetic medium for microcalorimetric studies (Section 2.2.(a)(iii)).

Figure 2.3

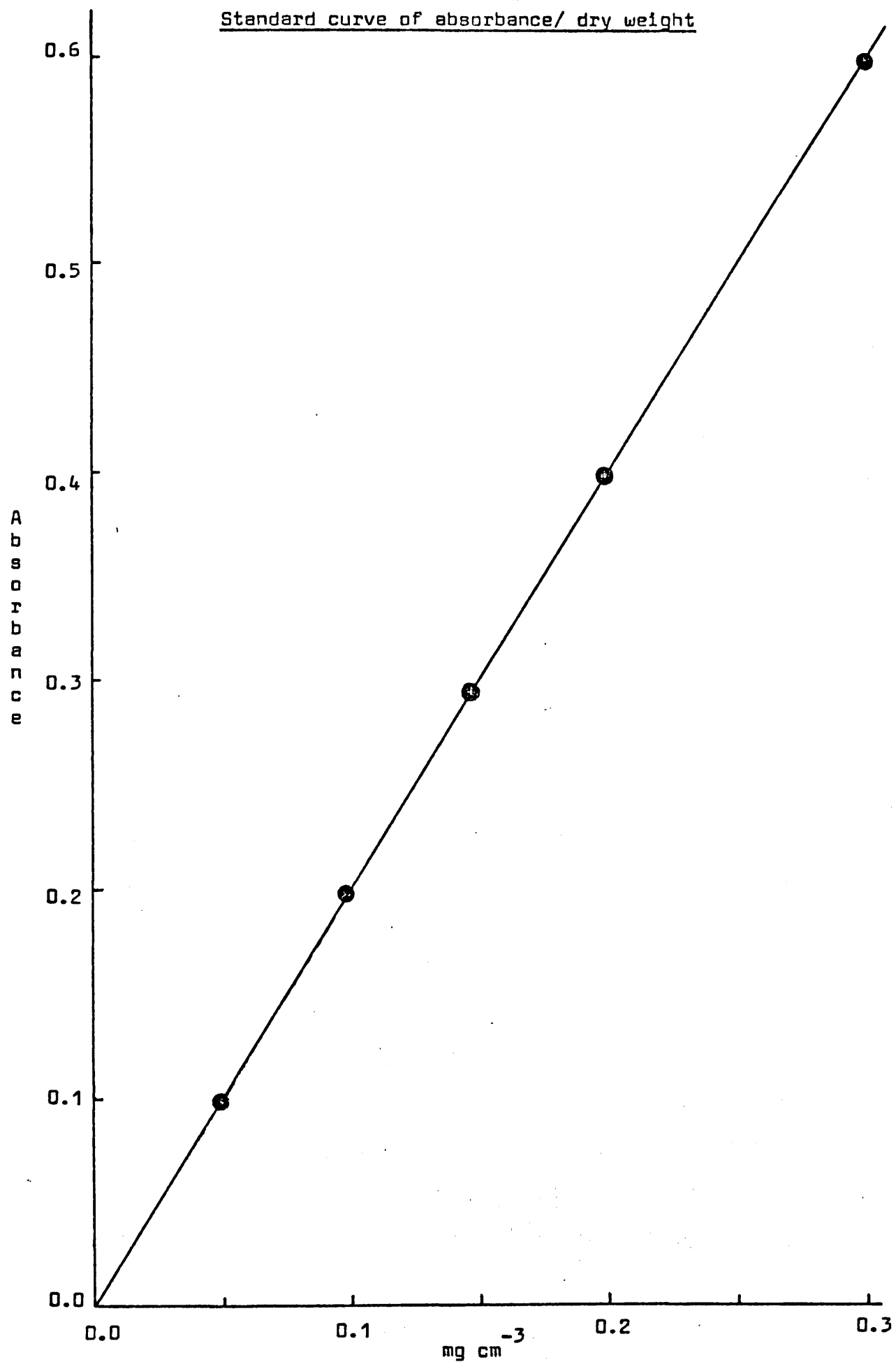
Standard curve of absorbance/ dry weight

2.3.(c) Lipid analysis

(i) Determination of lipid content of bacterial cells

For lipid extraction, the procedure used was a modification of the method of Vaczi et al (1964). About 500 mg of finely powdered dry bacterial cells of each strain were refluxed for 18 h with a chloroform/methanol (2:1 v/v) mixture at 75 °C. The filtrate was then separated from the cell residue using a millipore filter. This procedure was repeated three times, refluxing the cell residue with fresh solvent each time. The combined filtrate was then distilled at 55-60 °C to drive off the bulk of the solvent and the remaining 5 cm³ of extract transferred to a clean, dry tared weighing bottle. Fresh solvent was used to wash out the flask and the washings added to the extract. The solvent was then removed completely by evaporation at 60-70 °C under an inert atmosphere of oxygen-free nitrogen. The lipid remaining in the weighing bottle was finally dried to constant weight over P₂O₅ in a vacuum desiccator. The weight of lipid obtained for each strain was then used to calculate the lipid content of that strain, expressed as a percentage of dry cell weight. The lipid samples obtained were stored over P₂O₅ in vacuo until required for analysis.

(ii) Analysis of lipid components

Thin layer chromatography on silica gel plates was used to resolve the lipid extracts into their constituent components. The ascending technique was employed to produce the chromatograms. Three different solvent systems were used in separate experiments on the

lipid samples. These were (1) chloroform/methanol/water, 65:25:4 v/v/v (Vaczi *et al*, 1964), chromatograms developed by this system were run for 1½-2 h; (2) light petroleum/diethyl ether/acetic acid, 80:20:1 v/v/v, chromatograms developed for 40-50 minutes; (3) n-hexane/diethyl ether/acetic acid/methanol, 90:20:2:3 v/v/v/v (Brown and Johnson, 1962), chromatograms developed for 50-60 minutes.

Lipid samples (dissolved in chloroform/methanol) were applied to the plates using micropipettes, the diameter of the applied spots not exceeding 3 mm. During sample application the plates were covered with filter paper to avoid the uptake of atmospheric moisture. The plates were then developed at room temperature in lined tanks.

The different fractions separated on the chromatograms were identified as far as possible by comparison with authentic samples run in parallel, by their R_f values and by their reaction with specific locating agents. The following locating agents were used:

- | | |
|-----------------------------|---|
| (a) iodine vapour | general detection |
| (b) sulphuric acid | general detection |
| (c) phosphomolybdic acid | non-specific lipid detection |
| (d) molybdenum solution | detection of phosphorus |
| (Dittmer and Lester, 1964) | |
| (e) Dragendorff's reagent | specific for choline-containing phospholipids |
| (Elvidge and Sammers, 1966) | |
| (f) ninhydrin | detection of amino groups |

The relative abundance of the different lipid components separated on the chromatograms was determined by first charring with

sulphuric acid and then scanning the plates with a microdensitometer. The intensity of each of the various spots was plotted as a function of their distance along the plates. The area beneath the curve for each spot, which was proportional to the amount of that lipid component present, was then measured.

2.3.(d) Amino acid analysis

About 30 mg of powdered, dry cells were hydrolysed in 5 cm³ of 6 mol dm⁻³ HCl at 120 °C for 24 h in a sealed glass ampoule. The hydrolysate was poured into an evaporating basin and heated to near dryness. Distilled water was then added and the hydrolysate again heated until most of the liquid had evaporated. Distilled water was added a second time and the process repeated again. The residue was then transferred quantitatively to a 5 cm³ volumetric flask using distilled water. Finally the 5 cm³ was added to 5 cm³ of buffer solution to give a solution of fixed pH (~ 2). This procedure was carried out in duplicate for each strain analysed. An E.E.L. (Hastead, Essex) amino acid analyser was used to determine the relative amounts of the different amino acids present in the samples.

2.3.(e) Chemical analysis of cell suspensions

After dry weight determinations using the standard absorbance against dry weight curve, each suspension was analysed as quickly as possible. Standard curves were produced each time the analytical techniques were used.

(i) Polysaccharide was estimated by the anthrone method. The anthrone reagent was prepared fresh each time by adding 30 cm³ of distilled water to 0.2 g of anthrone in a 250 cm³ conical flask and then slowly adding 100 cm³ of concentrated sulphuric acid, cooling the flask under running water at the same time. When no anthrone remained undissolved and the solution was cool, 8 cm³ of absolute ethanol was added and the reagent again cooled. 1 cm³ portions of test suspension (in duplicate), standard glucose solutions or saline blank, were pipetted into boiling tubes standing in an ice bath and 10 cm³ of anthrone reagent was then added to each. The tubes were transferred to a boiling water bath for 10 minutes and finally cooled in the ice bath again. The absorbance of each of the green solutions was measured at 625 nm against the saline blank (using a P.E. 124 spectrophotometer) and the polysaccharide contents read off the standard curve.

(ii) Protein was assayed by the Biuret method. 3 cm³ samples of suspensions (in duplicate), standard solutions (bovine serum albumin) or saline blank were pipetted into boiling tubes standing in an ice bath. Then 1.5 cm³ of 3.0 mol dm⁻³ sodium hydroxide solution was added to each tube and the tubes placed in boiling water for 10 minutes. The tubes were then cooled in an ice water bath and 1.5 cm³ of 5% copper sulphate solution was added to each. The tubes were then sealed with parafilm and each shaken thoroughly. After standing for 15 minutes at room temperature the solutions were transferred to 25 cm³ universal bottles and the bottles centrifuged for 15 minutes to remove the precipitated Cu(OH)₂. The absorbance of each of the violet supernatants was measured at 550 nm

and the protein content of the test suspensions obtained from the standard curve.

(iii) For RNA and DNA analysis, duplicate 9 cm^3 of suspensions were treated with perchloric acid to extract the nucleic acids. The suspensions were first centrifuged and the cells suspended in 5 cm^3 of 0.2 mol dm^{-3} perchloric acid for 20 minutes to remove free nucleic acid. The suspensions were then centrifuged and the cells transferred in 15 cm^3 of 0.5 mol dm^{-3} perchloric acid to 50 cm^3 glass stoppered flasks. These were heated for 30 minutes at 70°C during which time they were shaken. Then the temperature was slowly raised to 85°C , the flasks being shaken occasionally. After this the flasks were cooled and their contents transferred to 25 cm^3 universal bottles. The flasks were then rinsed out with 2 cm^3 of 0.5 mol dm^{-3} perchloric acid and the rinsings added to the contents of the universal bottles. After centrifuging, the supernatants were removed from the cell debris and the DNA and RNA contents determined.

DNA was estimated by the diphenylamine method (Burton, 1956). To make the reagent, 1 g of diphenylamine was dissolved in 100 cm^3 of glacial acetic acid and then 2.75 cm^3 of concentrated sulphuric acid was added. This solution was stored in the dark. When it was required for use, 0.1 cm^3 of a 16 mg cm^{-3} aqueous acetaldehyde solution was added to 20 cm^3 of the reagent. 3 cm^3 of this final diphenylamine solution was then added to 1.5 cm^3 of supernatant solutions, standard DNA solutions (calf thymus DNA) or perchloric acid (for blank) in boiling tubes. The tubes were closed with glass marbles and left overnight in a water bath at 30°C . The absorbance of each of the blue solutions was measured at 595 nm and the DNA

content thus determined using the calibration curve.

RNA was assayed by using the orcinol method. The reagents were: 1 g of orcinol in 10 cm³ of absolute alcohol and 33 mg of iron (III) chloride in 100 cm³ of concentrated hydrochloric acid. 0.3 cm³ of the orcinol reagent and 3 cm³ of iron (III) chloride solution were added to 3 cm³ of extract, standard solutions (yeast RNA) or perchloric acid (blank) in boiling tubes. These were then capped with glass marbles, heated for 45 minutes in a boiling water bath and cooled to room temperature. The absorbance of each of the green solutions was measured at 667 nm and the RNA content read from the calibration curve.

CHAPTER 3

MICROCALORIMETRIC STUDIES OF THE GROWTH OF CELLS

OF K. AEROGENES IN DRUG-FREE MEDIUM

3.1 Growth of *K. aerogenes* in Synthetic Medium at 37 °C

Fresh sterile culture medium (2 g dm^{-3} glucose) under aeration at 37 °C, was pumped in alternate air/liquid segments through the flow cell of the microcalorimeter and the baseline established (2.2.(a)(ii)) for a period of about an hour. The medium was then inoculated with cells from an 18 h culture of *K. aerogenes* grown in synthetic medium (also 2 g dm^{-3} of glucose) and the rate of heat output expressed as an output voltage, recorded for 16 to 18 h.

The absorbance of the culture at different times was converted into the biomass/mg cm^{-3} (from the dry weight v absorbance curve (Section 2.3.(b)(ii)), and log biomass was plotted against time (Figure 3.2). The mean generation time (mgt) was about 38 minutes. The large inoculum used resulted in a negligible lag phase, which was followed by the phase of exponential growth. The population at the stationary phase was about 10^9 cells cm^{-3} .

The difference between the output voltage and the baseline is a measure of the heat output. This difference was converted into the heat output (Watts) by multiplying by the calibration constant of the microcalorimeter. This constant was determined at the end of an experiment by adding formalin to the culture, applying a measured current through a resistance ($\sim 50 \Omega$) in the microcalorimeter cell, and recording the heat output. The measured thermogram (Figure 3.1) is a record of the bacterial heat output against time.

After inoculation there was a short time interval before the growing culture reached the calorimeter cell. A smooth increase of heat output with time was then recorded until the culture had

Figure 3.1

Growth of cells of K. aerogenes in
drug-free medium

———— measured thermogram

- - - - - specific thermogram

- - - - - O₂ tension

● — ● — Glucose concentration

———— Log (dry wt/mg cm⁻³)

- . . . - pH

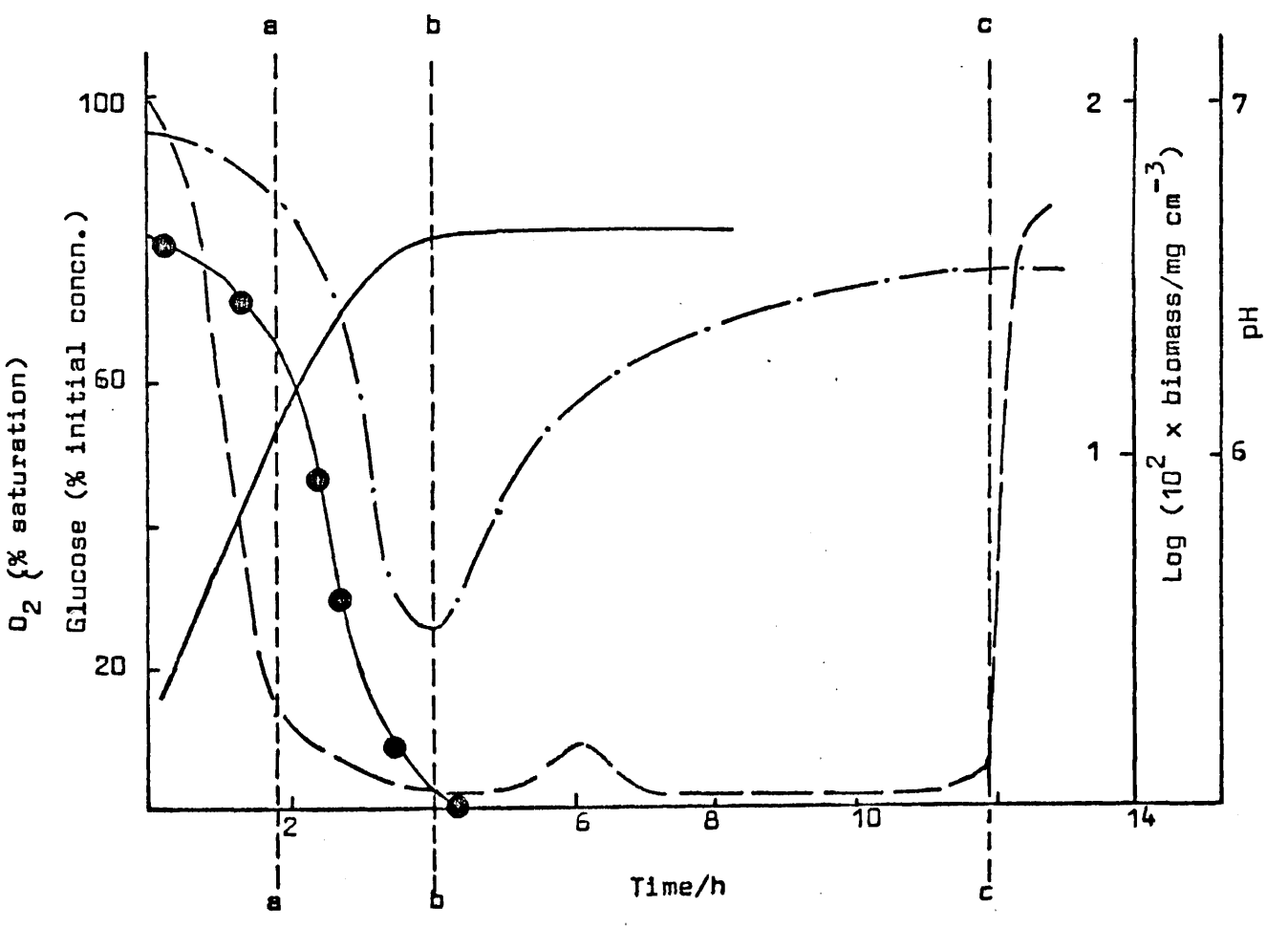
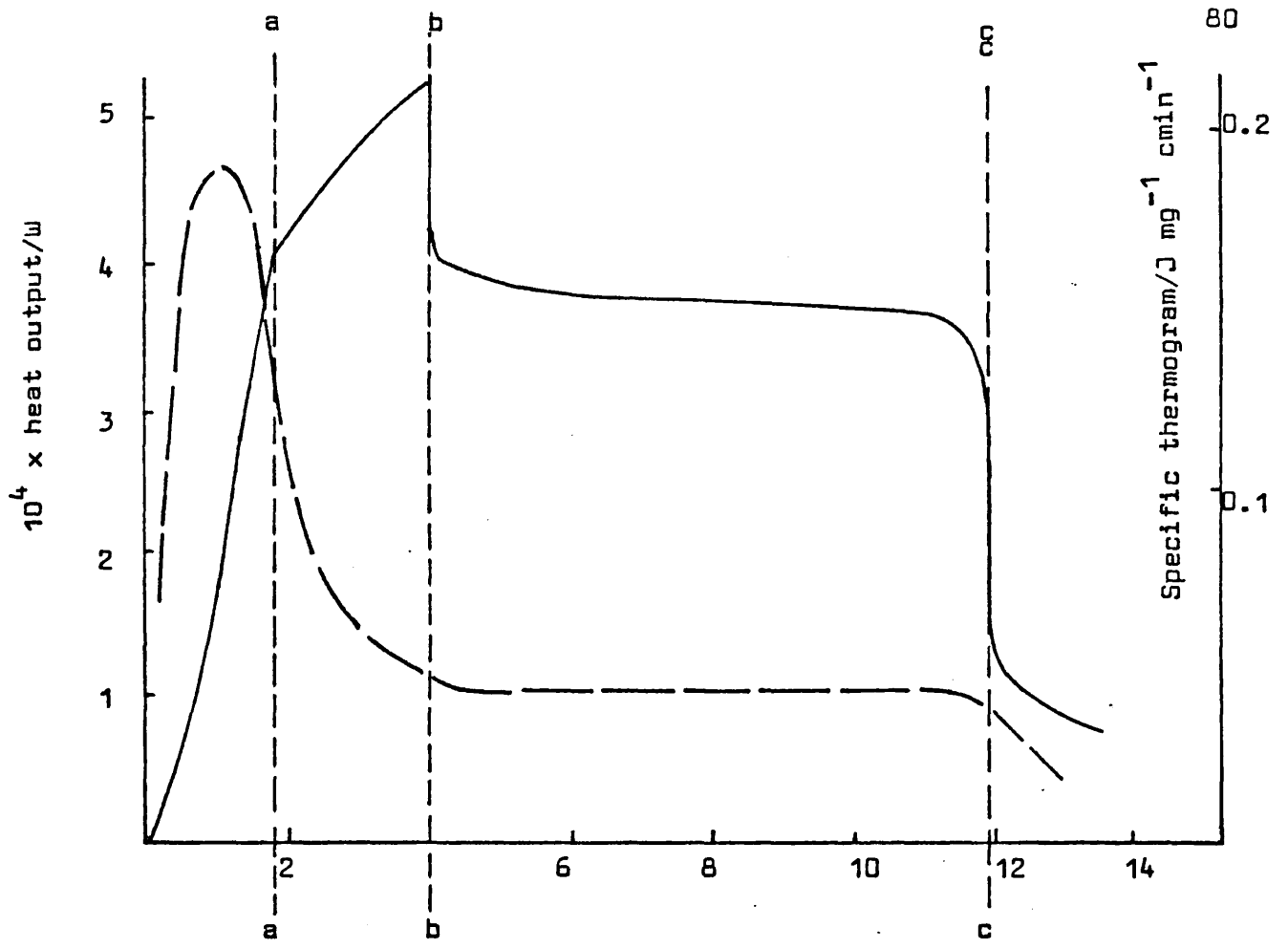

been growing for about 2 h, and had attained a biomass of about 0.13 mg cm^{-3} , (aa in Figure 3.1). There was then a marked reduction in the rate of increase of heat output; the increase of heat output continued at the new slower rate until the stationary phase was reached (after about 4 h of growth), at which point a sharp fall in heat output occurred (bb in Figure 3.1). Subsequently the heat output decreased slowly until a second and larger sharp decrease occurred, cc. The baseline was not re-established under normal circumstances, presumably due to basal endogenous metabolic processes. However, the addition of formalin to kill the bacteria always resulted in the re-establishment of the baseline.

The specific thermogram (Figure 3.1), expressing the heat evolved per unit biomass per minute ($\text{J mg}^{-1} \text{ min}^{-1}$), was obtained by integrating the original heat output-time traces over short time intervals and dividing this by the dry weight of organism in the calorimeter cell at the mid-point of the time interval. Most heat was released during the exponential phase of growth, during which time the shape and position of the specific thermogram is virtually independent of the initial glucose concentration (Few *et al*, 1976). The maximum value was in the range 0.18 to $0.25 \text{ J mg}^{-1} \text{ min}^{-1}$. After attaining the maximum value, the heat evolved decreased until the stationary phase was reached, bb, after which the specific thermogram levelled off until the point cc, where there was a sharp fall in heat output.

Oxygen tension (expressed as a percentage of the value for air saturated water) decreased during the exponential phase of growth. This decrease is independent of the initial glucose

concentration (Few et al, 1976). A low oxygen tension value ($\sim 15\%$) was always attained at about the same time as the first break, aa, in the thermogram. This represents a considerable oxygen depletion in the culture medium. At the start of the stationary phase there was a brief increase in the oxygen tension, which then returned to the previous level. This increase in oxygen tension and the period for which it was maintained depends on the initial glucose concentration, being greatest during growth in the lowest glucose concentration. This pulse was followed by a period of time (greatest for the lowest glucose concentration) when there was reduced oxygen tension (about 2-5%). Finally, the second decrease in heat output, cc, was accompanied by an increase of the oxygen tension to a high value.

There was little change in the pH of the culture (Figure 3.1) during the initial stages of growth. After the first break in the thermogram, aa, the pH decreased considerably, reaching a minimum value at the onset of the stationary phase. By the time of the second sharp fall in heat output, cc, the pH had increased and attained a value of ~ 6.5 , slightly lower than that of the original culture medium. After this the pH of the culture remained constant.

During the exponential growth phase the extracellular glucose concentration (Figure 3.1) decreased sharply, attaining a zero value within 30 minutes of the onset of the stationary phase, bb. The extracellular glucose concentration is expressed as a percentage of the initial glucose concentration of the growth medium, and plotted at the mid-point of the time interval of 30-40 minutes,

over which the sample was collected. The final bacterial population depended on the initial glucose concentration.

Table 3.1 shows the summarised results for three separate experiments using the same growth medium (2 g dm^{-3} of glucose). In the table the heat evolved recorded in the various phases of the growth cycle and the total heat, refer to the heat given out by the bacteria present in the calorimeter cell, i.e. in a volume of 1.2 cm^3 . This (i.e. the total area under the thermogram) also includes heat produced by resting organisms.

Table 3.1

Heat evolved and other environmental properties during
the growth of cells of *K. aerogenes* at 37°C

Experiment	Heat evolved/J				Biomass /mg cm^{-3}		Min. pH	% oxygen tension at aa
	0-aa*	aa-bb	bb-cc	Total	aa	bb		
1	1.17	3.83	9.6	14.6	0.12	0.46	5.42	16
2	1.07	3.73	9.6	14.4	0.13	0.46	5.48	15
3	1.05	3.85	9.8	14.7	0.11	0.43	5.4	15

* Where 0 represents the point of inoculation

It is apparent that, using the standard techniques established in this Department, the heat evolved by the organisms during the different phases of the growth cycle and the total heat evolved is constant within the limits of error of the microcalorimeter. Although it is difficult to fully assess error limits, it is reasonable to accept it to be better than $\pm 6-7\%$. Thus differences in heat output for organisms of greater than 10% are significant. This reproducibility makes it possible to study changes in heat output brought about as a result of growth under different conditions (e.g. in the presence of antibacterial agents), and relate them to changes in metabolic processes. The technique of continual monitoring of the absorbance has been shown to be very reproducible (Figure 3.2).

The abrupt changes in heat output are a direct reflection of changes in oxygen tension. Thus when the oxygen tension reaches 15% at aa, at a biomass of 0.13 mg cm^{-3} , there is an abrupt reduction in the rate of heat output. At the onset of the stationary phase, when complete oxygen depletion has occurred and glucose utilization is complete, bb, there is another abrupt change in heat output. This is presumably due to a change from metabolic processes necessary for growth and division, to secondary metabolic processes concerned with the oxidation of accumulated glucose breakdown products, possibly acetate, lactate or pyruvate. These processes require large amounts of oxygen for the working of the Krebs cycle and the electron transport pathways, and are very exothermic. When all the secondary processes are finished, cc, there is an increase in the oxygen tension and a decrease in the heat output to a level where only maintenance or basal processes are occurring.

Figure 3.2

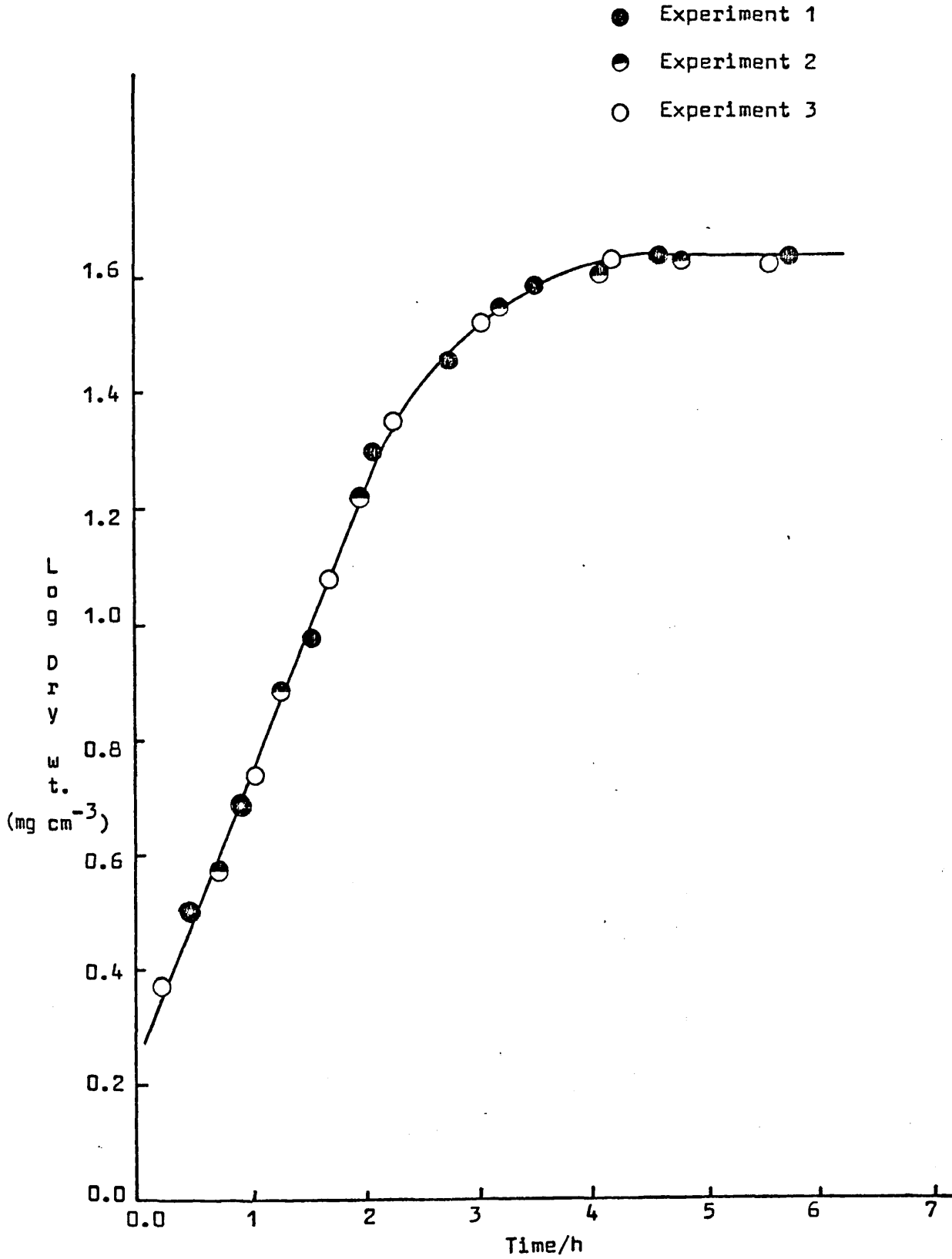
Growth curve of *K. aerogenes* in simple salt medium

This experiment has been repeated using different glucose concentrations. The general pattern of changes during growth are qualitatively similar to those shown in Figure 3.1. The results are summarised in Table 3.2.

Table 3.2

Heat evolved and other environmental properties during the growth of cells of *K. aerogenes* in synthetic medium containing different concentrations of glucose

Glucose conc/g dm ⁻³	Heat evolved/J				Biomass /mg cm ⁻³		Min. pH	% oxygen tension at aa
	0-aa	aa-bb	bb-cc	Total	aa	bb		
2.0	1.1	3.8	9.6	14.5	0.13	0.46	5.45	15
1.0	1.2	1.6	4.2	7.0	0.13	0.37	6.4	15
0.5	1.2	1.0	2.3	4.5	0.13	0.22	6.7	15

The oxygen tension at aa is independent of glucose concentration, whilst the minimum pH value at bb decreases with increasing glucose concentration. The biomass at aa and the heat evolved between inoculation and aa are also independent of glucose concentration. The biomass at the start of the stationary phase, bb, and the heat evolved between aa and bb, between bb and cc, and as a consequence the total heat evolved, are all directly dependent

upon the glucose concentration of the growth medium. The total heat evolved is approximately proportional to the glucose concentration.

3.2 Chemical Analysis of Supernatant

Samples of bacterial culture (which had passed through the heated tube) were collected at regular intervals during growth, centrifuged and the cell-free supernatant solution examined for possible acid products of fermentation. The lanthanum nitrate spot test and gas-liquid chromatography were used to test for the presence of acetic acid. Enzymatic kits (Boehringer, Mannheim GMBH) were used to test for the presence of lactic and pyruvic acids. Only acetate was detected in the supernatant solutions.

During the exponential phase of growth the oxygen tension in the medium becomes rapidly depleted. Less oxygen is then available for the oxidative metabolism of glucose via the Krebs cycle and fermentation occurs. The acid products (including acetic acid) of fermentation cause the pH of the growth medium to fall. Thus,

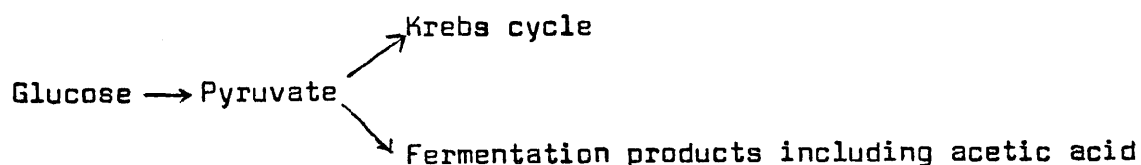

When the glucose becomes exhausted at the onset of the stationary phase the pH of the medium begins to increase again. Oxygen consumption remains high and there is still a substantial heat output. This suggests that the acidic products of fermentation are being metabolised by the cells. This metabolic activity continues

until the pH of the medium returns to a higher value (~ 6.5), i.e. until the acidic substrate becomes depleted.

To investigate this hypothesis experiments were performed in which various amounts (0.1 to 0.13 g) of either acetic, lactic or pyruvic acid were added in turn to cultures which had reached the late stationary phase (i.e. after cc in Figure 3.1). The results are shown in Figure 3.3. The changes in the thermogram, pH and oxygen tension are consistent with changes occurring during the stationary phase of the normal growth cycle. On addition of the acid, the pH of the culture decreased very rapidly in a similar way to that observed during the latter part of the exponential growth phase of normal growth. The oxygen tension then fell rapidly and the heat output rose. There was a considerable heat output for the next 60 to 90 minutes, thereafter decreasing rapidly. Each of the three acids gave a characteristic thermogram. The heat output after the addition of acetate was about 4 Watts (Figure 3.3). Lactic and pyruvic acid gave similar results. Subsequently the pH returned to its value before the addition of acid, the oxygen tension rose and the heat output fell to the previous value. Thus these experiments provide strong evidence that acid produced by fermentation during normal growth is oxidatively metabolised after the glucose becomes exhausted.

The total energy evolved after the addition of known amounts of acetic, pyruvic and lactic acids are shown in Table 3.3. The energy evolved per m mole of acid is also calculated.

If it is assumed that acetic acid alone is being metabolised between bb and cc, then from the total heat output of 9.6 J from

Figure 3.3

—— measured thermogram

--- O₂ tension

---:--- pH

l = addition of Acetic acid (1.74 mmol)

m = addition of Pyruvic acid (1.46 mmol)

n = addition of Lactic acid (1.33 mmol)

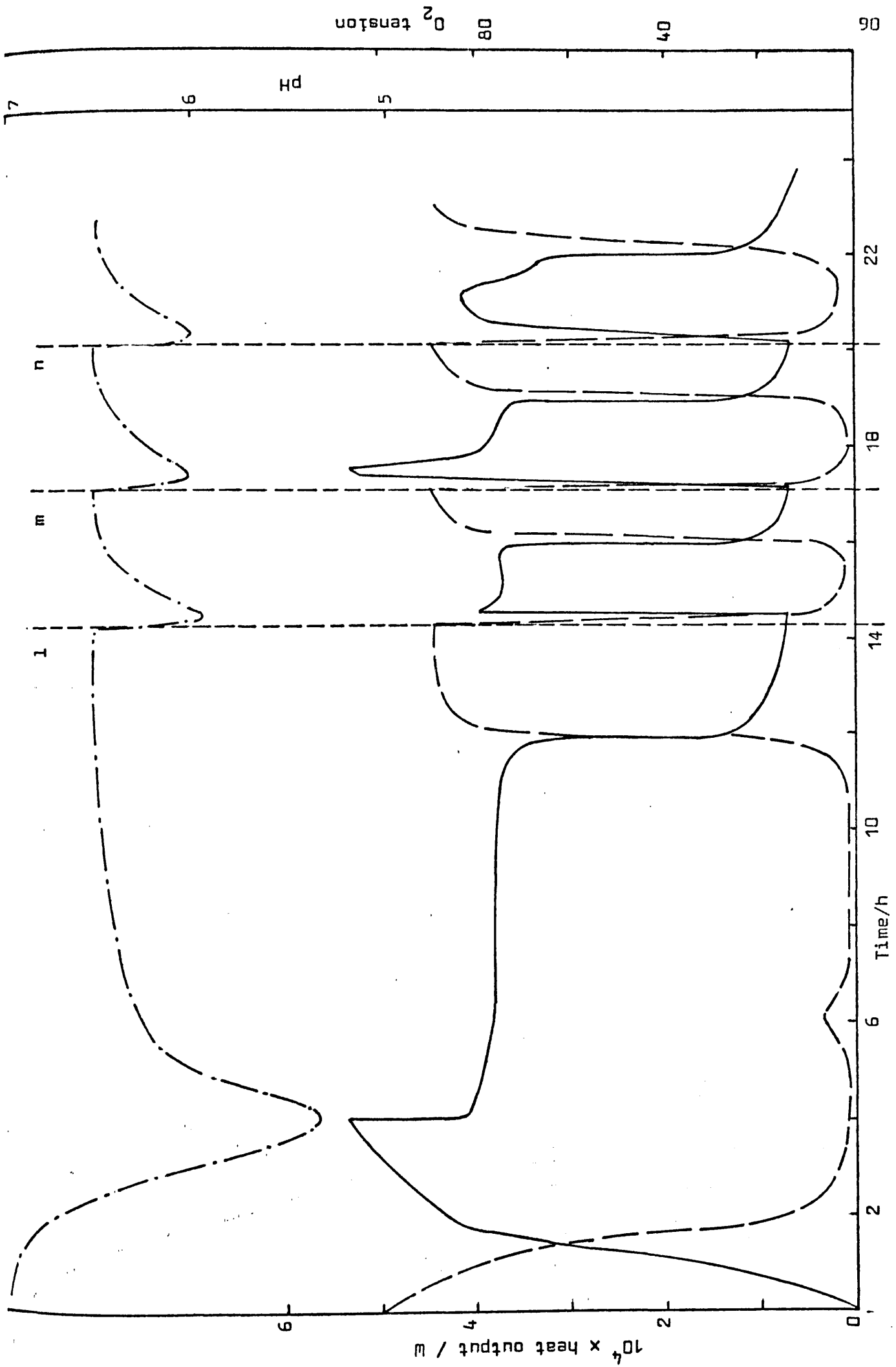

Table 3.3

Energy evolved after addition of acid

Acid	Acid added /m mol	Energy evolved* /J	Energy evolved for oxidation of acid /kJ mol ⁻¹	ΔH_c /kJ**
Acetic acid	1.74	2.3	550	-1004
Pyruvic acid	1.46	2.0	571	-1145
Lactic acid	1.33	1.75	548	-1352

* For organisms in 1.2 cm³ of culture

** Calculated heat of combustion

1.2 cm³ of culture during this period, the number of moles of acetic acid metabolised may be calculated as:

$$\frac{9.6}{1.32} = \underline{7.9 \times 10^{-3} \text{ mol}}$$

where 1.32 J was heat evolved when 1 mmol of acetic acid was metabolised.

3.3 Summary

- (a) Cells of K. aerogenes grown in synthetic medium displayed a characteristic thermogram. A fall in oxygen tension (to ~ 15%) lead to a rapid increase in fermentation by the growing culture. The stationary phase was reached when the glucose concentration in

the medium became depleted, although the organisms continued to metabolise for some time, using acid fermentation products as a substrate.

- (b) Analysis of cell-free supernatant suggested that acetic acid (but not pyruvic or lactic acid) was produced by the cells during the exponential growth phase.

CHAPTER 4

MICROCALORIMETRIC STUDIES OF THE GROWTH OF CELLS
OF K. AEROGENES IN THE PRESENCE OF ANTIBACTERIAL AGENTS

To make meaningful comparisons between the effects of different antibiotics and antibacterial agents on the growth of cells of K. aerogenes, it was necessary to standardise all techniques as far as possible. To achieve this the following conditions were observed:

- (a) a standard volume (600 cm^3) of medium of constant glucose concentration (2 g dm^{-3});
- (b) a standard volume (30 cm^3) of inoculum;
- (c) a standard age of inoculum (18 h);
- (d) standard conditions of pumping of $6-9 \text{ cm}^3 \text{ h}^{-1}$ through the microcalorimeter, and $400 \text{ cm}^3 \text{ h}^{-1}$ through the pH electrode, oxygen electrode and absorbance cell;
- (e) constant aeration of the growing culture with filtered air at a rate of $1 \text{ dm}^3 \text{ min}^{-1}$;
- (f) the bacteria were grown at standard drug concentrations of half the MIC of each antibiotic, as well as at other concentrations which were simple fractions or multiples of the MIC.

4.1 MIC values for different antibacterial agents

The MIC values (Section 2.1.(e)) for the strain of K. aerogenes for the different antibacterial drugs used in this investigation are listed in Table 4.1.

Table 4.1

MIC of different antibacterials for cells of *K. aerogenes*
during growth in synthetic medium

Antibacterial agent	MIC/ $\mu\text{g cm}^{-3}$
Penicillin	200
Carbenicillin	1000
Methicillin	1600
Gentamicin base	0.05
Nalidixic acid	6.0
Sulphanilamide	400
Proflavine	50

4.2 Growth of cells of *K. aerogenes* in the presence of penicillin G

The thermogram and values of environmental properties obtained during the growth of cells of *K. aerogenes* at 37 °C in simple salts/glucose medium containing 100 $\mu\text{g cm}^{-3}$ of penicillin are shown in Figure 4.1.

Immediately after inoculation the organisms grew normally (i.e. as in the absence of antibiotic); the heat output and bacterial mass increased and the oxygen tension decreased. After about an hour, however, the heat output and bacterial mass fell abruptly and the oxygen tension increased to almost its original value, indicating that

Figure 4.1 Untrained cells of *K. aerogenes* grown in presence of penicillin ($100 \mu\text{g cm}^{-3}$)

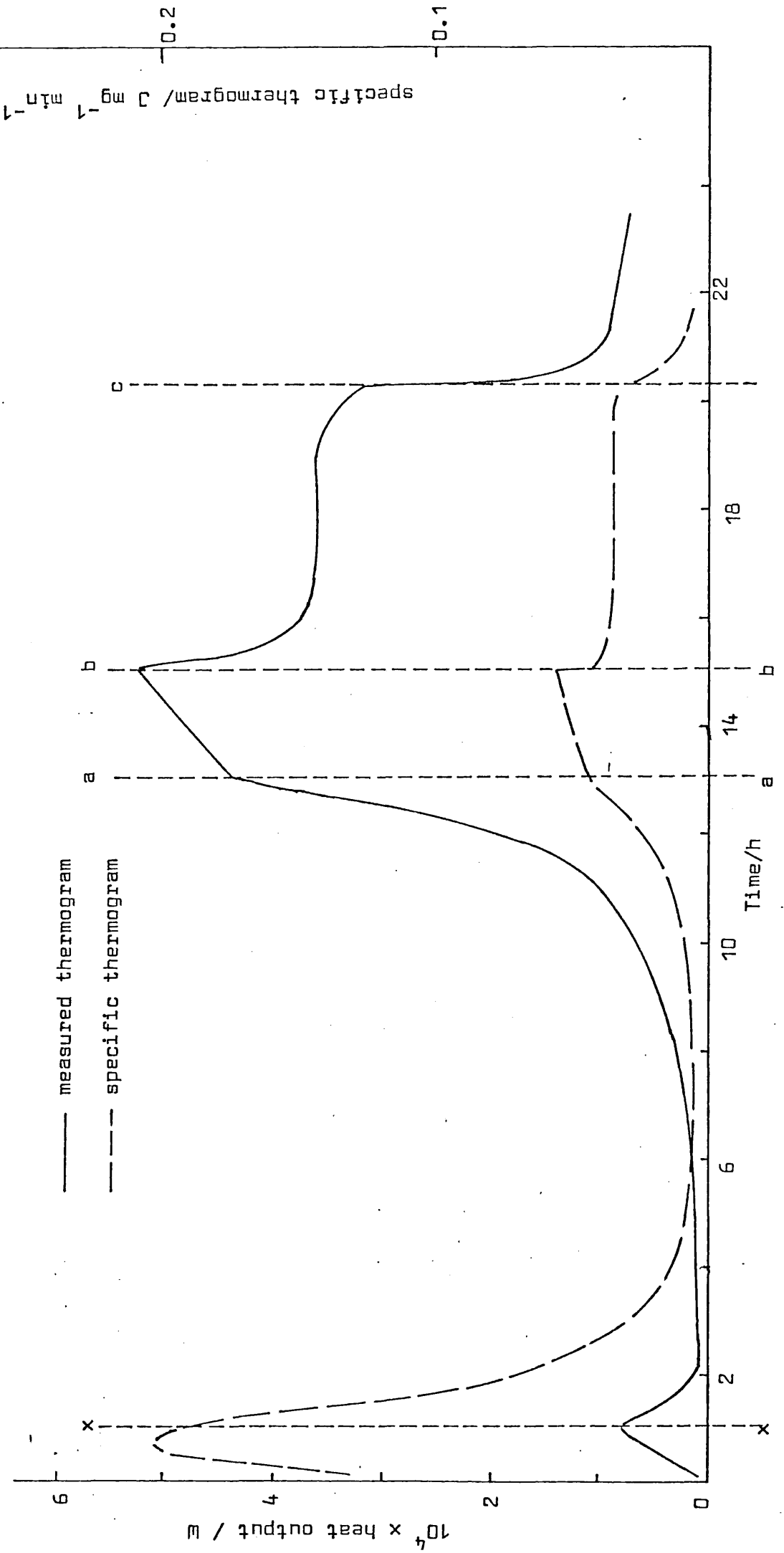

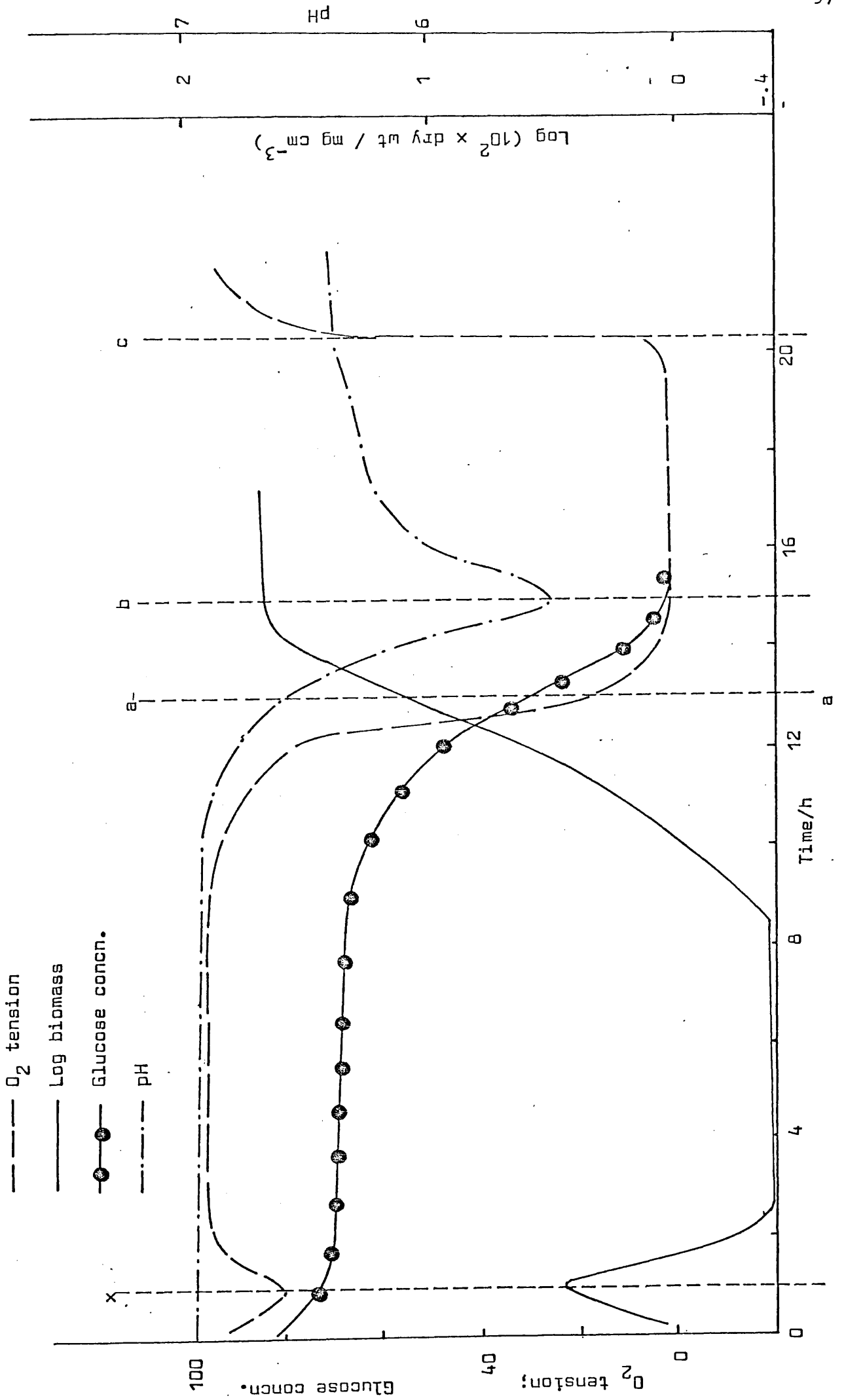

bacterial growth had ceased. This decrease in bacterial mass was due to cell lysis. A lag phase of about 8 h then followed, during which time there was no apparent growth. A slight increase in heat output was detected before the end of the lag phase, before there was any detectable growth. As yet, no microcalorimetric studies have been made on cells during a long lag phase in normal medium. At the end of this lag phase, growth was resumed and the characteristic patterns of change in heat output, oxygen tension, pH and biomass were observed, similar to those occurring during normal growth in drug-free medium. The results are summarised in Table 4.2.

The growth rate was slightly reduced after the resumption of growth compared with that of drug-free growth; the mgt was 40 minutes compared with 38 minutes for the control. The onset of the stationary phase, bb, was reached about 15 h after inoculation and the onset of the late stationary phase, cc, some $5\frac{1}{2}$ h later, compared with about 4 h and 12 h after inoculation for drug-free growth. The biomass at both aa and at the onset of the stationary phase, bb, was the same as when cells were grown in drug-free medium. The minimum value of the pH which also occurred at the onset of the stationary phase, bb, was not significantly different from that observed during growth in the absence of the antibiotic. The pH of the culture increased slightly between bb and cc, although it never attained the initial value. The heat evolved from the resumption of growth to aa was slightly increased compared with that from inoculation to aa in drug-free medium. The heat output between aa (the stage at which the oxygen tension was about 15% and the biomass about 0.13 mg cm^{-3} as in the control) and bb (the onset of the stationary

Table 4.2

Heat evolved and associated properties during the growth of cells of K. aerogenes in the presence of penicillin antibiotics

Concentration / $\mu\text{g cm}^{-3}$	Inoc. to xx/min	Lag/h	mgt/min		Heat evolved/J per 1.2 cm^3				Biomass/ mg cm^{-3}					
			Before lysis	After lysis	Init. growth	lag phase	end of lag-aa	aa-bb	bb-cc	Total	xx	aa	bb	Min.pH
0 (Control)	-	-	38	38	-	-	1.1	3.8	9.6	14.5	-	0.13	0.46	5.45
<u>Penicillin</u>														
100	60	6	42	40	0.3	0.6	1.6	3.9	6.4	12.8	0.03	0.13	0.47	5.55
200	42	11.25	40	48	0.2	0.8	2.3	3.5	6.2	13.0	0.03	0.14	0.47	5.6
400 (Trained)	-	0.25	38	38	-	-	1.4	3.7	9.0	14.0	-	0.14	0.47	5.5
<u>Methicillin</u>														
200	150	4.5	41	82	3.5	0.2	1.1	3.1	3.8	11.0	0.22	0.17	0.38	6.0
800	120	6	39	76	2.0	0.1	1.6	3.7	4.3	11.7	0.12	0.17	0.39	5.8
<u>Carbenicillin</u>														
50	-	0.5	42	42	-	-	1.2	3.7	9.2	14.1	-	0.14	0.47	5.5
100	102	4.25	52	38	0.9	0.02	1.3	3.6	8.0	13.8	0.06	0.14	0.45	5.5
500	54	10	52	48	0.2	0.01	1.4	3.3	4.9	9.8	0.03	0.15	0.46	5.65

phase) was not affected by the presence of the drug. However, the heat output during the stationary phase when secondary metabolic processes were occurring, between bb and cc, was less than that in the control. The total heat evolved between inoculation and cc was in consequence less during growth in the presence of penicillin.

As a result of the initial period of growth, the glucose concentration during the lag phase was only 70% of the initial amount. The glucose concentration in the medium became depleted at the onset of the stationary phase, bb, as it did for growth in drug-free medium. In all experiments on the growth of cells of K. aerogenes in the presence of antibacterial drugs, glucose was always depleted at bb; the glucose concentration will therefore not always be shown on subsequent diagrams. The smaller amount of heat evolved, 70% of the control value, in the region bb to cc is most probably due to the initial reduction of glucose concentration prior to cell lysis. The glucose utilized in this early part of the growth cycle will be completely metabolised. Only the glucose broken down during the exponential growth phase will provide products for secondary metabolism.

Cells of K. aerogenes were also grown in medium containing penicillin at a concentration of $200 \mu\text{g cm}^{-3}$ (Table 4.2). Although the general pattern of initial growth phase, lysis and subsequent lag phase was similar to that observed during growth in the presence of $100 \mu\text{g cm}^{-3}$ of penicillin, the lag phase was longer and the growth rate less. The heat evolved during the initial growth and lag phases was slightly higher than during growth at the lower concentration. The mgt after the lag phase was increased from 40 to 48 minutes and

the heat evolved from the end of the lag phase to aa was also greater than that of the control or of cells growing at the lower penicillin concentration. The final biomass was unaffected by the increased concentration of antibiotic.

At the end of each of these experiments, samples were taken and the MIC of penicillin again determined, against cells which had grown once in the presence of the antibiotic. The MIC values were unchanged by growth in the presence of these particular concentrations of penicillin, indicating that the cells had not acquired any increased level of resistance.

Cells of K. aerogenes were trained to grow in the presence of $400 \mu\text{g cm}^{-3}$ of penicillin in synthetic medium(2.1.(d)). A thermogram and related environmental data was then obtained during the growth of these trained cells in the presence of $400 \mu\text{g cm}^{-3}$ of penicillin (Table 4.2). The shape and position of the thermogram and changes in the other environmental properties were similar to those occurring during growth of untrained cells in drug-free medium. A brief lag phase of about 15 minutes immediately after inoculation, was followed by exponential growth (mgt=38 minutes). Although there were slight differences in the heat outputs in the regions aa-bb and bb-cc, compared with control cells (i.e. untrained cells), nevertheless the total heat evolved during the growth cycle was the same as the control cells. Thus repeated growth in the presence of penicillin had resulted in changes, whereby when growing in the presence of the antibiotic, the growth pattern and the heat evolved are of the normal type, characteristic of control cells.

4.3. Growth of cells of *K. aerogenes* in the presence of methicillin and carbenicillin

Cells of *K. aerogenes* were also grown in the presence of the penicillin antibiotics, methicillin (200 and 800 $\mu\text{g cm}^{-3}$) and carbenicillin (50, 100 and 500 $\mu\text{g cm}^{-3}$).

The same general pattern of cell lysis, lag and final bacterial growth observed in the presence of penicillin G, was again observed during growth in media containing these concentrations of methicillin and carbenicillin. The results are also summarised in Table 4.2. Growth in the presence of 50 $\mu\text{g cm}^{-3}$ of carbenicillin was exceptional in that after a short lag phase, growth was normal with no lysis occurring. The heat output in each of the regions and the total heat evolved were the same as for growth in normal medium. At other concentrations of these antibiotics, initial growth was followed by a fall in bacterial mass due to cell lysis, and then a lag phase and finally growth until the stationary phase was reached. The lengths of time between the different phases varied with concentration as with penicillin. The initial growth stage became shorter and the time for resumption of subsequent growth became longer with increasing concentration. At these concentrations of the antibiotics there was a considerable reduction in the total heat evolved by the organisms. This suggests that in attempting to overcome the presence of the antibiotic, the cells used up some of the energy which is otherwise dissipated as heat.

Figure 4.2 shows a comparison of the thermograms recorded during growth in the presence of comparable concentrations ($\frac{1}{2}$ MIC) of the three different antibiotics. The effects of the antibiotics

Figure 4.2 A comparison of the thermograms recorded during growth in the presence of comparable concn. (1/2 MIC) of the penicillins

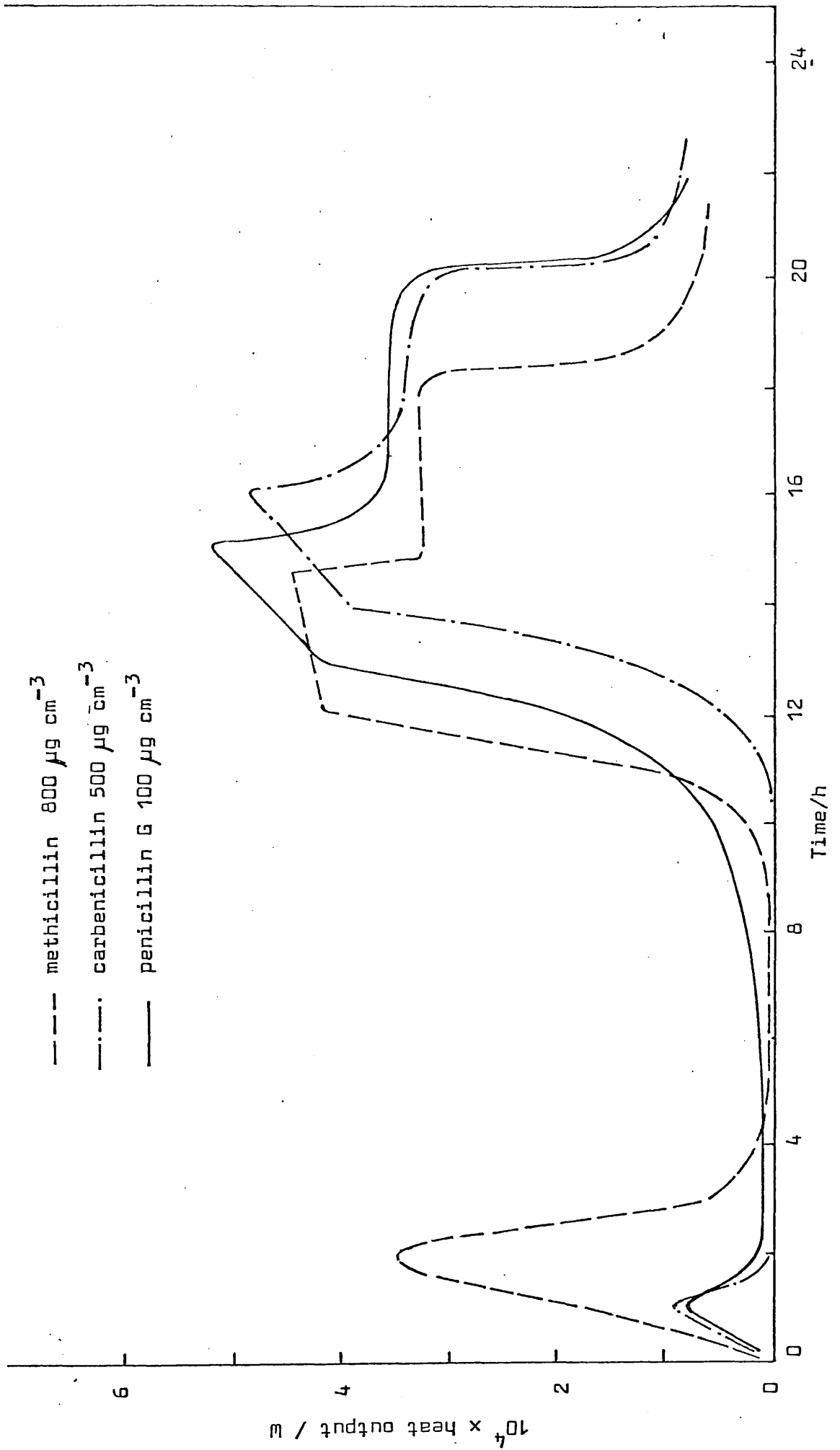

on the heat output by the organisms with time were similar; methicillin required the longest time to cause cell lysis, whilst carbenicillin prevented the resumption of growth for slightly longer than the other drugs. The cells grew to a much greater biomass at xx and consequently gave out a greater amount of heat during the initial growth phase, when growing in the presence of methicillin, than in the presence of the other two drugs. This growth at both concentrations of methicillin was sufficient to cause oxygen depletion and corresponding fall in pH to values of 6.55 and 6.65 for growth in the presence of 200 and 800 $\mu\text{g cm}^{-3}$ of methicillin respectively (Figure 4.3). These pH values remained constant for some hours before decreasing slowly until the more abrupt fall at aa.

The heat evolved between the end of the lag phase and aa (the stage where the oxygen tension falls to about 15% and the biomass is about 0.13 mg cm^{-3}) during growth in the presence of 200 $\mu\text{g cm}^{-3}$ of methicillin and 50 $\mu\text{g cm}^{-3}$ of carbenicillin, was the same as that during the growth of cells in drug-free medium. Higher concentrations of these antibiotics resulted in a slightly increased heat evolution in this region (as with penicillin). The increase was very small with carbenicillin at the concentrations used. The heat evolved between aa and bb was slightly less in the presence of higher concentrations of carbenicillin compared with growth in the absence of antibiotics, but was the same for the higher concentration of methicillin. The heat evolved between bb and cc was reduced, probably due to slower growth rate, and the total heat evolved was in consequence less than that of control cells. These observations were thus broadly the same as for growth in the presence of penicillin.

Figure 4.3 Untrained cells of K. aerogenes grown in the presence methicillin (200 ug cm⁻³)

— — — — — O₂ tension

— . — . — . — . pH

— ● — ● — Glucose (% initial concn.)

————— Log biomass

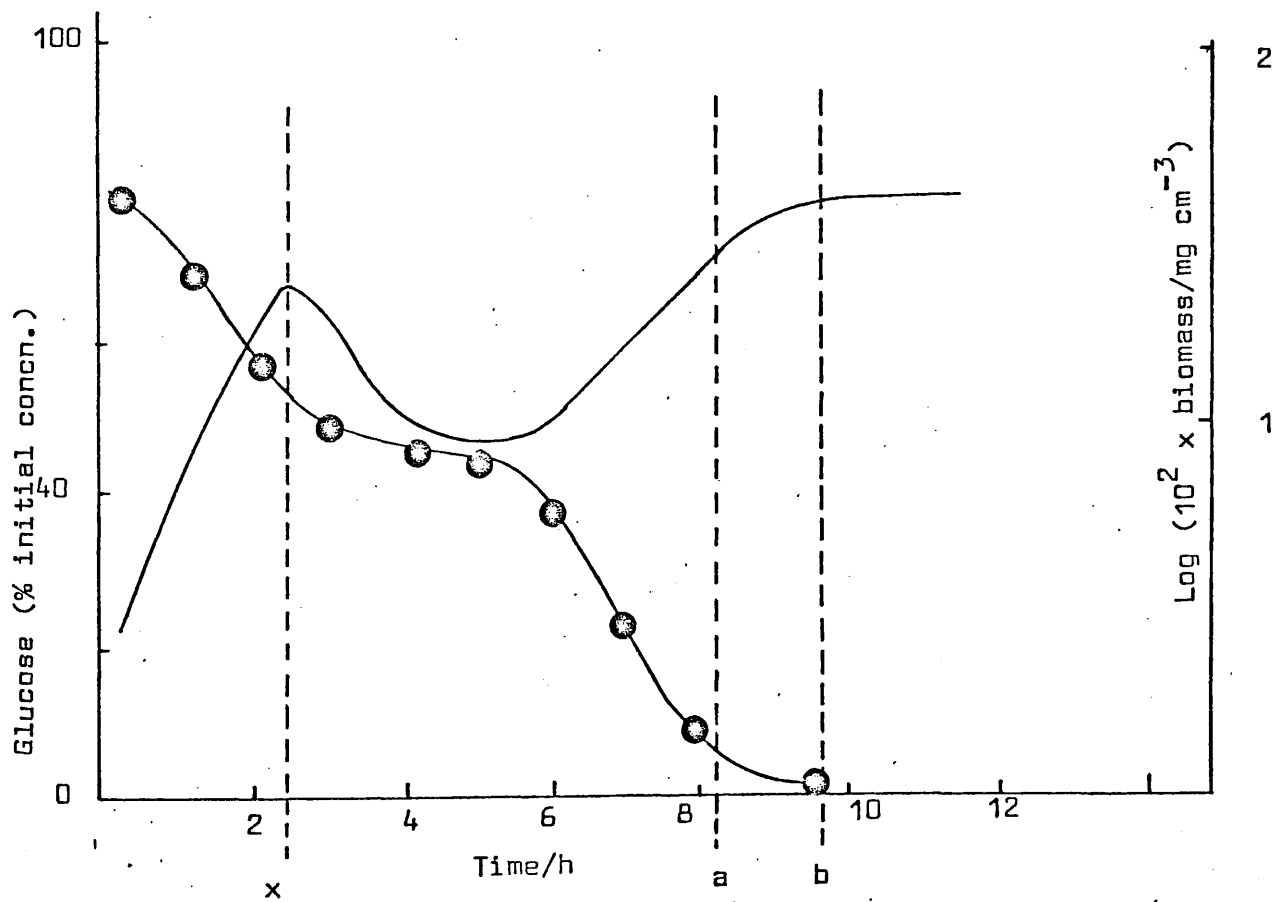
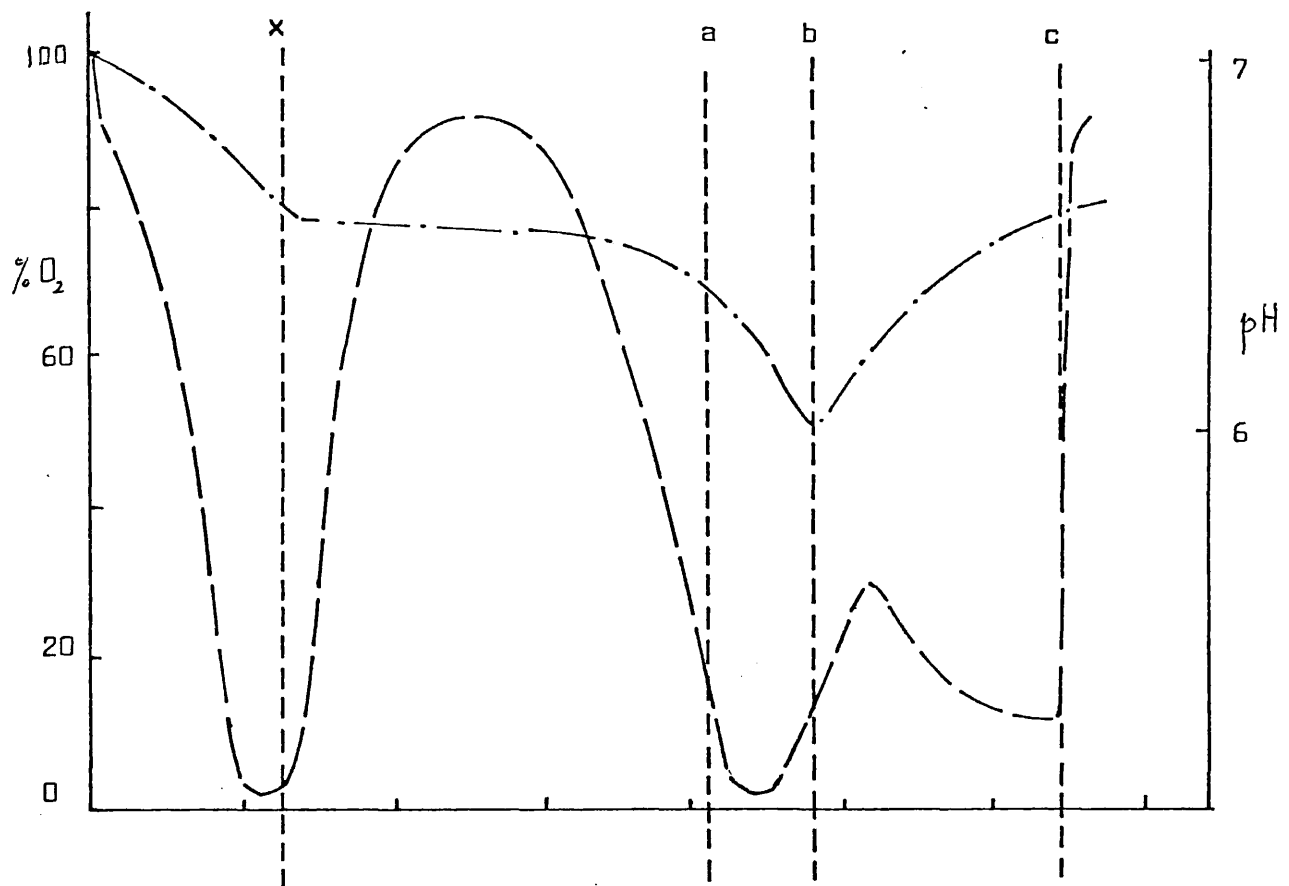

Again, as with penicillin, the biomass at aa and at bb was unaltered by the presence of different concentrations of carbenicillin in the growth medium. With methicillin however, the biomass was slightly higher at aa and significantly lower at bb than the corresponding biomass obtained during drug-free growth. The biomass, both at aa and at bb was independent of methicillin concentration. The mgt after the lag phase was much greater in the presence of methicillin than in its absence. The mgt in the presence of $500 \mu\text{g cm}^{-3}$ of carbenicillin was slightly greater than that of the control.

Growth in the presence of all the penicillin antibiotics caused a decrease in the pH. The minimum value, which was always attained at the onset of the stationary phase, was slightly higher after growth in the presence of methicillin than that after growth in the presence of penicillin G or carbenicillin.

Viable counts were made during growth of cells in the presence of $100 \mu\text{g cm}^{-3}$ of carbenicillin. Immediately after inoculation the count was about 4×10^6 organisms cm^{-3} . This rose to about 10^7 organisms cm^{-3} before the onset of lysis and then fell to about 2×10^6 organisms cm^{-3} . This count remained constant during the lag phase and then rose to about 10^{10} organisms cm^{-3} at the onset of the stationary phase.

A sample was taken at the end of one experiment in which cells had been grown in medium containing $100 \mu\text{g cm}^{-3}$ of carbenicillin, and used to inoculate media containing different concentrations of penicillin, carbenicillin and methicillin. The general shape of the thermograms and other environmental properties accompanying growth in $100 \mu\text{g cm}^{-3}$ of carbenicillin and $200 \mu\text{g cm}^{-3}$ of methicillin

Table 4.3

Heat evolved during growth in the presence of penicillin
antibiotics of cells of K. aerogenes which had previously
grown once in the presence of 100 $\mu\text{g cm}^{-3}$ of carbenicillin

Concentration $\mu\text{g cm}^{-3}$	mgt/min	Heat evolved/J				Biomass /mg cm^{-3}		Min. pH
		0-aa	aa-bb	bb-cc	Total	aa	bb	
0 (Control)	38	1.1	3.8	9.6	14.5	0.13	0.46	5.45
<u>Carbenicillin</u>								
100	37	1.2	3.3	8.7	13.2	0.12	0.46	5.5
300	36 . 63*	1.5	3.5	6.2	11.2	0.13	0.45	5.65
<u>Penicillin</u>								
100	37 51*	1.4	3.7	7.0	13.1	0.14	0.46	5.6
<u>Methicillin</u>								
200	37	1.4	3.6	9.0	14.0	0.13	0.46	5.5

* mgt after brief lag phase.

(Table 4.3) were similar to those of normal cells grown in drug-free medium (except that the heat output between aa and bb, and between bb and cc was slightly lower for growth in the presence of carbenicillin). When these cells, grown once in carbenicillin, were used to inoculate medium containing 100 $\mu\text{g cm}^{-3}$ of penicillin or 300 $\mu\text{g cm}^{-3}$ of carbenicillin, an initial growth period followed by a short lag phase, were detected from the heat output and other data. No lysis

was observed. A normal pattern of growth at reduced rates was then resumed. In both of these cases the heat evolved between inoculation and aa was slightly higher than that for growth of normal cells in drug-free medium, whilst the heat evolved between bb and cc was significantly lower than that for growth in drug-free medium. The total heat evolved was also significantly lower for growth in this concentration of carbenicillin than for drug-free growth. The minimum pH values in all these experiments was similar to that observed for untrained cells grown in drug-free medium. It thus appears that the original, single growth at a concentration of $100 \mu\text{g cm}^{-3}$ of carbenicillin had given the cells some degree of resistance and cross-resistance to other penicillin antibiotics.

4.4 Growth of cells of *K. aerogenes* in the presence of gentamicin

Cells of *K. aerogenes* were grown in medium containing gentamicin sulphate at concentrations of 0.025, 0.1 and $0.2 \mu\text{g cm}^{-3}$ (expressed as gentamicin base). The results of thermograms and environmental data obtained during these experiments are summarised in Table 4.4.

The general shapes of the thermograms and the changes of oxygen tension and pH with time, for growth in the presence of 0.025 and $0.1 \mu\text{g cm}^{-3}$ of gentamicin were similar to those observed during growth in drug-free medium. Growth in the presence of $0.025 \mu\text{g cm}^{-3}$ of gentamicin caused a marked reduction in the rate of growth (mgt=52 minutes); the stationary phase was reached about 5 h after

Table 4.4

Heat evolved and associated properties during the growth
of K. aerogenes in the presence of gentamicin

Concentration / $\mu\text{g cm}^{-3}$	mgt/min	Heat evolved/J				Biomass /mg cm^{-3}		Min. pH
		0-aa	aa-bb	bb-cc	Total	aa	bb	
0 (Control)	38	1.1	3.8	9.6	14.5	0.13	0.46	5.45
0.025	52	1.6	4.2	8.7	14.5	0.13	0.46	5.6
0.1	68	1.8	5.0	7.8	14.6	0.13	0.46	5.8
0.2	69	18.4	6.7	9.4	34.5	0.17	0.46	5.7
0.2 (Trained cells)	54	1.7	4.6	9.3	15.6	0.14	0.46	5.55

inoculation. The heat evolved between inoculation and aa, and between aa and bb was greater during growth in the presence of the antibiotic as compared with that for growth in drug-free medium. The heat output in the stationary phase, i.e. bb to cc, however, was less. The total heat evolved was the same as for control cells growing in the absence of antibiotic. The biomass at aa and at bb was the same for growth both in the absence and presence of the antibiotic.

When cells were grown in the presence of $0.1 \mu\text{g cm}^{-3}$ of gentamicin, the growth rate was further reduced (mgt=68 minutes), the stationary phase beginning about $6\frac{1}{2}$ h after inoculation. The heat

evolved during the growth phase, i.e. between inoculation and aa, and between aa and bb was greater, and the heat evolved between bb and cc was smaller, than that recorded during growth in the presence of $0.025 \mu\text{g cm}^{-3}$ of gentamicin. The total heat evolved was the same as for growth at the lower concentration (and in drug-free medium). The biomass was unaffected by the presence of this concentration of gentamicin.

Growth of cells at the higher gentamicin concentration of $0.2 \mu\text{g cm}^{-3}$ resulted in a markedly different thermogram and specific thermogram from those obtained during growth in drug-free medium (Figure 4.4). After inoculation an initial phase of growth was detected by changes in biomass, heat output and oxygen tension. This growth ceased after about one hour and was followed by a lag phase of about 9 h duration. When growth was resumed the growth rate gradually increased from an initial mgt of about 240 minutes to a final mgt of about 67 minutes. The final biomass was again the same as for growth in drug-free medium. The thermogram was unusual in two respects: (a) there was a considerable amount of heat evolved during the lag phase before logarithmic growth commenced, and (b) the point of maximum heat output occurred at aa, where the oxygen tension attains a value of 15%, instead of at the onset of the stationary phase, bb. The heat output fell sharply after aa, reaching a plateau value at bb, the start of the stationary phase. The heat evolved during secondary metabolic processes between bb and cc was the same as for growth in drug-free medium. The heat evolved from inoculation to aa, from aa to bb and also the total heat evolved was considerably higher than that given out

Figure 4.4 Untrained cells of *K. aerogenes*
 grown in the presence of gentamicin ($0.2 \mu\text{g cm}^{-3}$)

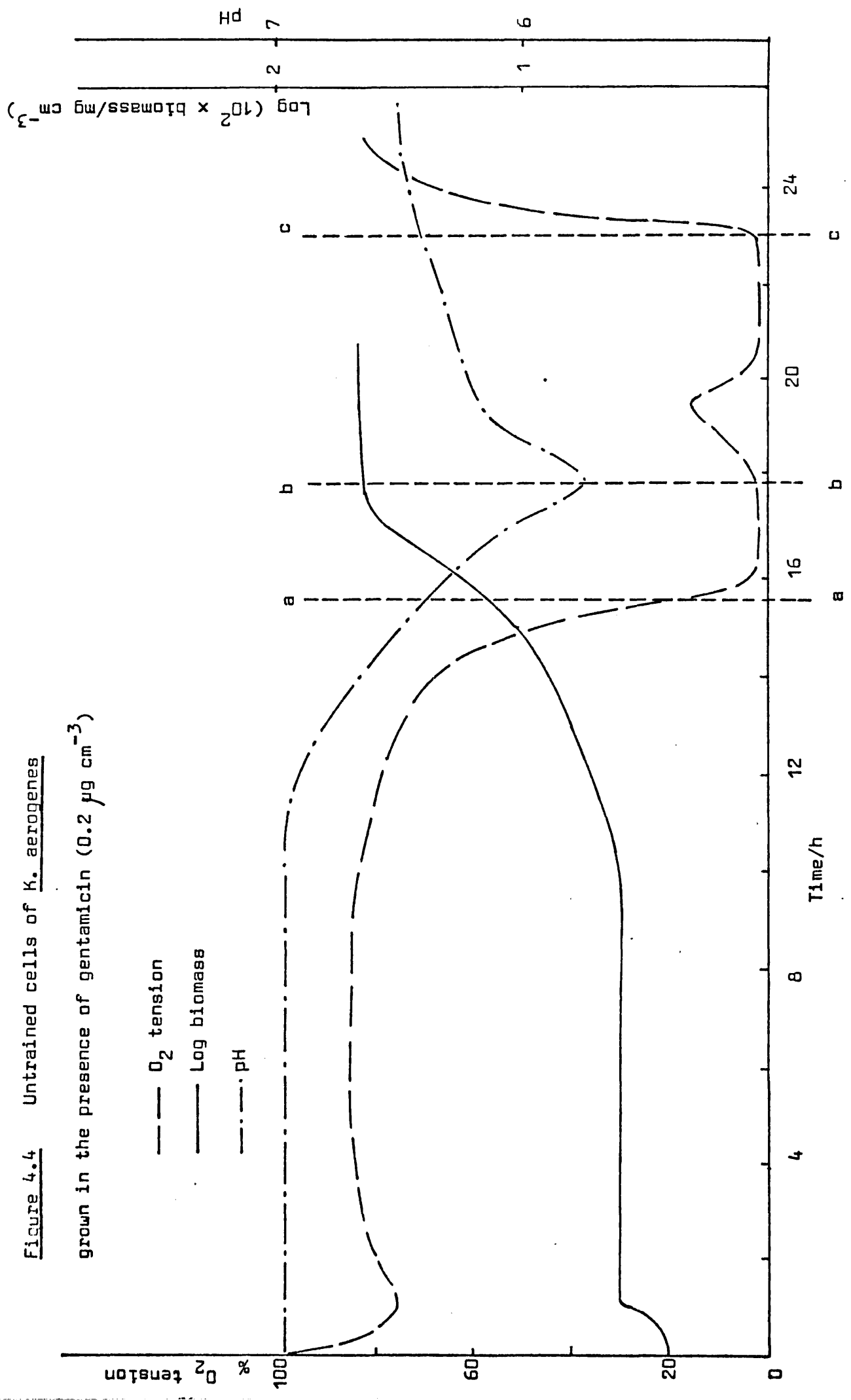

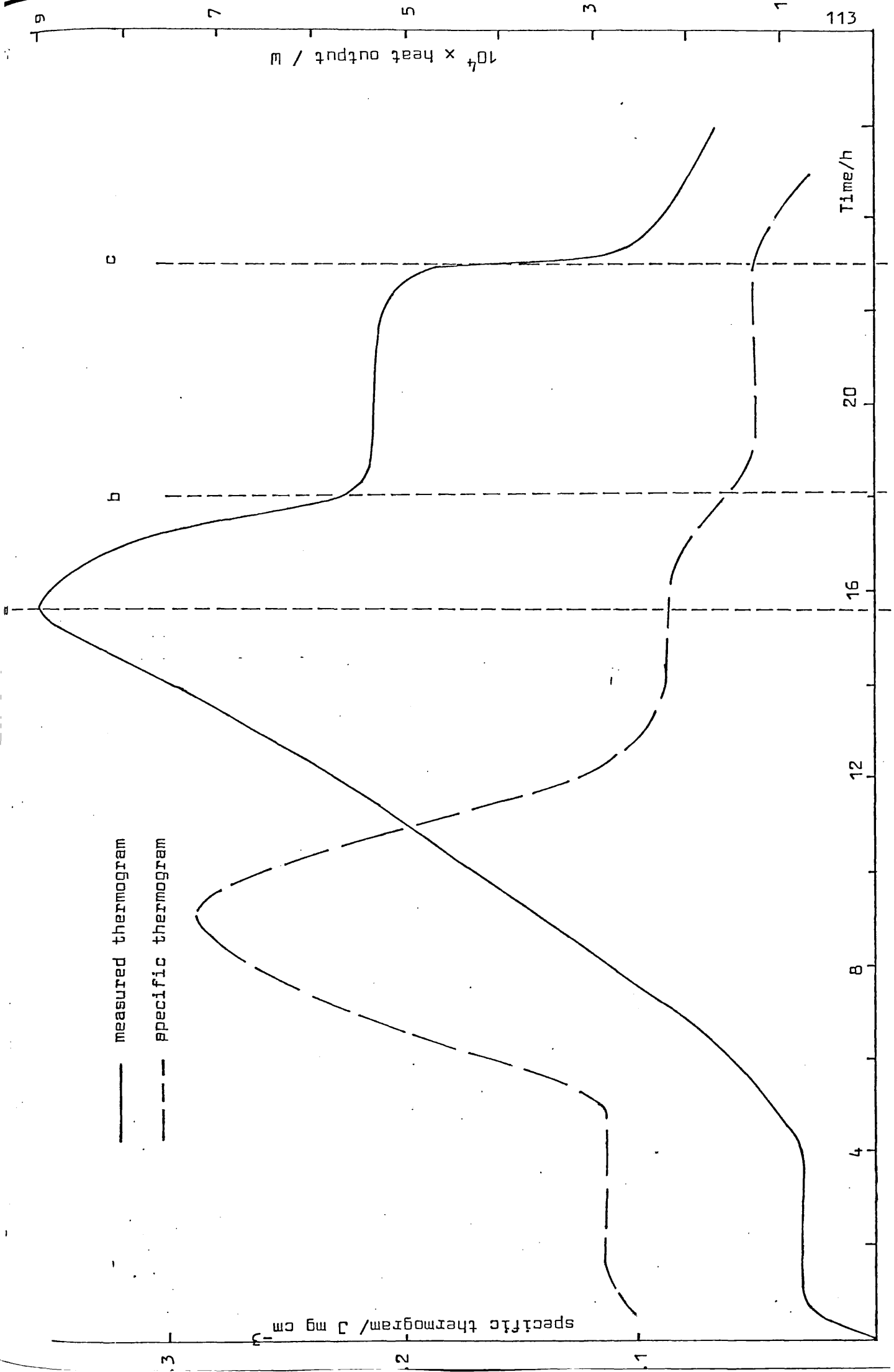

— measured thermogram
- - - specific thermogram

specific thermogram / J mg cm⁻³

$10^4 \times \text{heat output} / \text{W}$

Time/h

during growth in drug-free medium or at a lower concentration of gentamicin. The specific thermogram revealed that the specific heat output ($\text{J mg}^{-1} \text{min}^{-1}$) was about 1.5 times the normal value in drug-free medium, and attained a maximum value during the lag phase instead of during the exponential phase as normal. The minimum pH values of the medium during growth in each of these three gentamicin concentrations, which was slightly higher than that during the growth of cells in drug-free medium, was attained at the onset of the stationary phase.

Cells of K. aerogenes were trained to grow in the presence of $0.2 \mu\text{g cm}^{-3}$ of gentamicin (Section 2.1.(d)). After 50 consecutive subcultures in the presence of gentamicin, the cells were used to inoculate medium containing $0.2 \mu\text{g cm}^{-3}$ of gentamicin, and the thermogram and environmental properties recorded during subsequent growth. The results are summarised in Table 4.4. As a result of this training, the trained cells exhibited a thermogram more characteristic of the normal pattern, with the total heat evolved during growth approaching the value for growth in drug-free medium. There was no lag phase and accompanying large heat output for these trained cells as was observed with the growth of untrained cells at this gentamicin concentration. The stationary phase was reached some 5-6 h after inoculation and the mgt was 54 minutes, in both cases a reduction of the figure for untrained cells growing at this concentration. The heat evolved between inoculation and aa, between aa and bb and the total heat evolved was considerably reduced as compared with that of the untrained cells growing at this concentration. The biomass at aa and at bb was the same as for growth

of untrained cells in drug-free medium and at other gentamicin concentrations.

The results of the batch-cell microcalorimetric experiments on the interaction of cells of K. aerogenes with gentamicin are discussed in Section 5.4.

4.5 Growth of cells of K. aerogenes in the presence of nalidixic acid

The changes in heat output and other environmental properties during growth in the presence of low concentrations ($\sim \frac{1}{2} \times \text{MIC}$) of nalidixic acid were the same as for control cells grown in the absence of the drug. At higher concentrations (30 and $42 \mu\text{g cm}^{-3}$) these properties were markedly altered (Figure 4.5). The results are summarised in Table 4.5.

After cells were inoculated in synthetic medium containing $30 \mu\text{g cm}^{-3}$ of nalidixic acid, there was an initial growth phase for about $5\frac{1}{2}$ h, attaining a constant biomass at yy. This was accompanied by an increasing heat output and a fall in oxygen tension to about 75%. This growth phase was followed by a lag phase of about 6 h duration, during which time the heat output decreased, the oxygen tension increased to 90% and the biomass decreased slightly. After the lag phase, the cells grew exponentially, reaching the stationary phase at bb, as with growth in drug-free medium. However, unlike growth in drug-free medium, the heat output did not fall to a plateau value after bb, but fell slightly and then rose rapidly to produce a second peak. The heat output then declined

Figure 4.5 Untrained cells of *K. aerogenes* grown
in the presence of nalidixic acid ($42 \mu\text{g cm}^{-3}$)

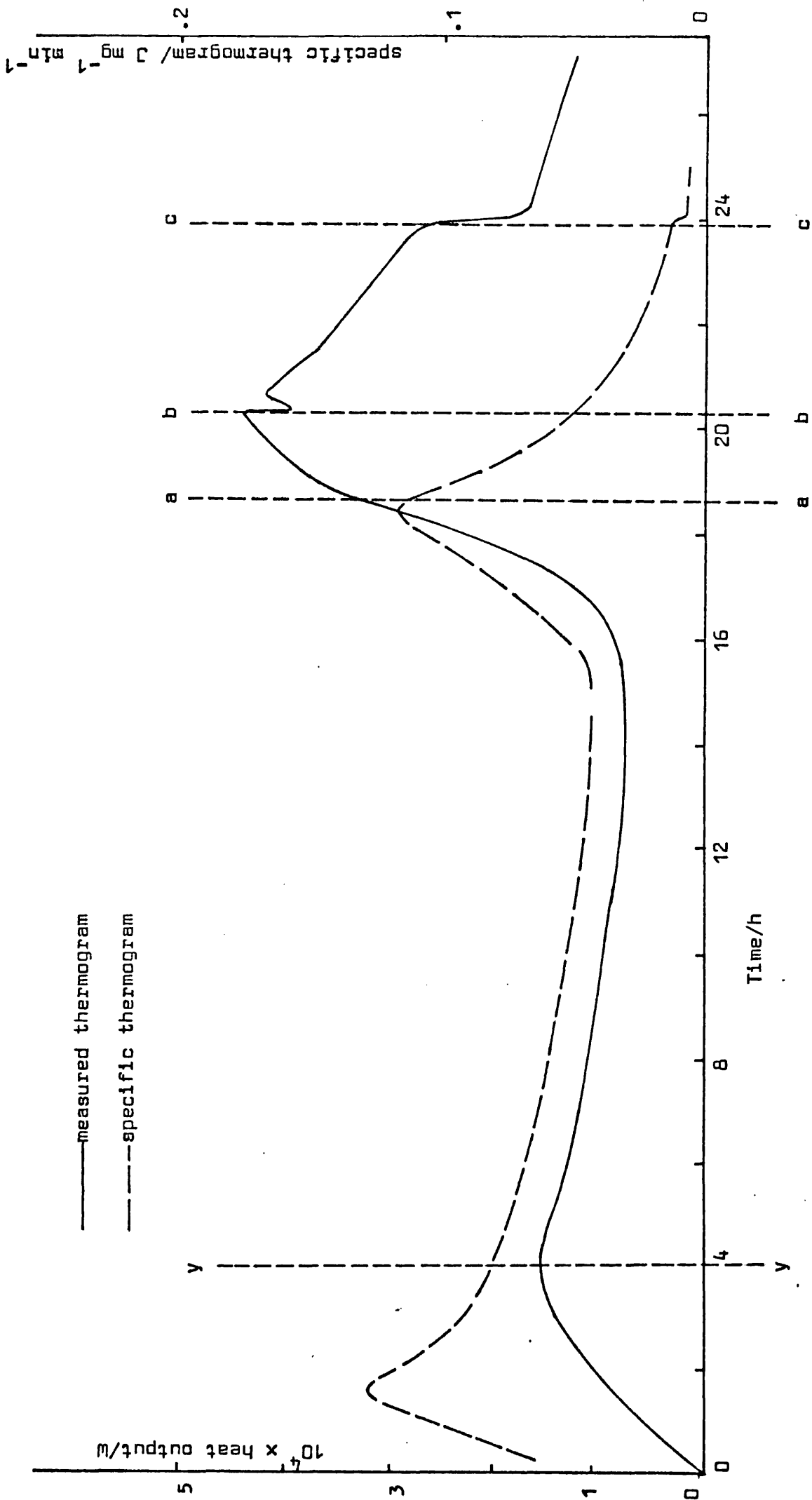

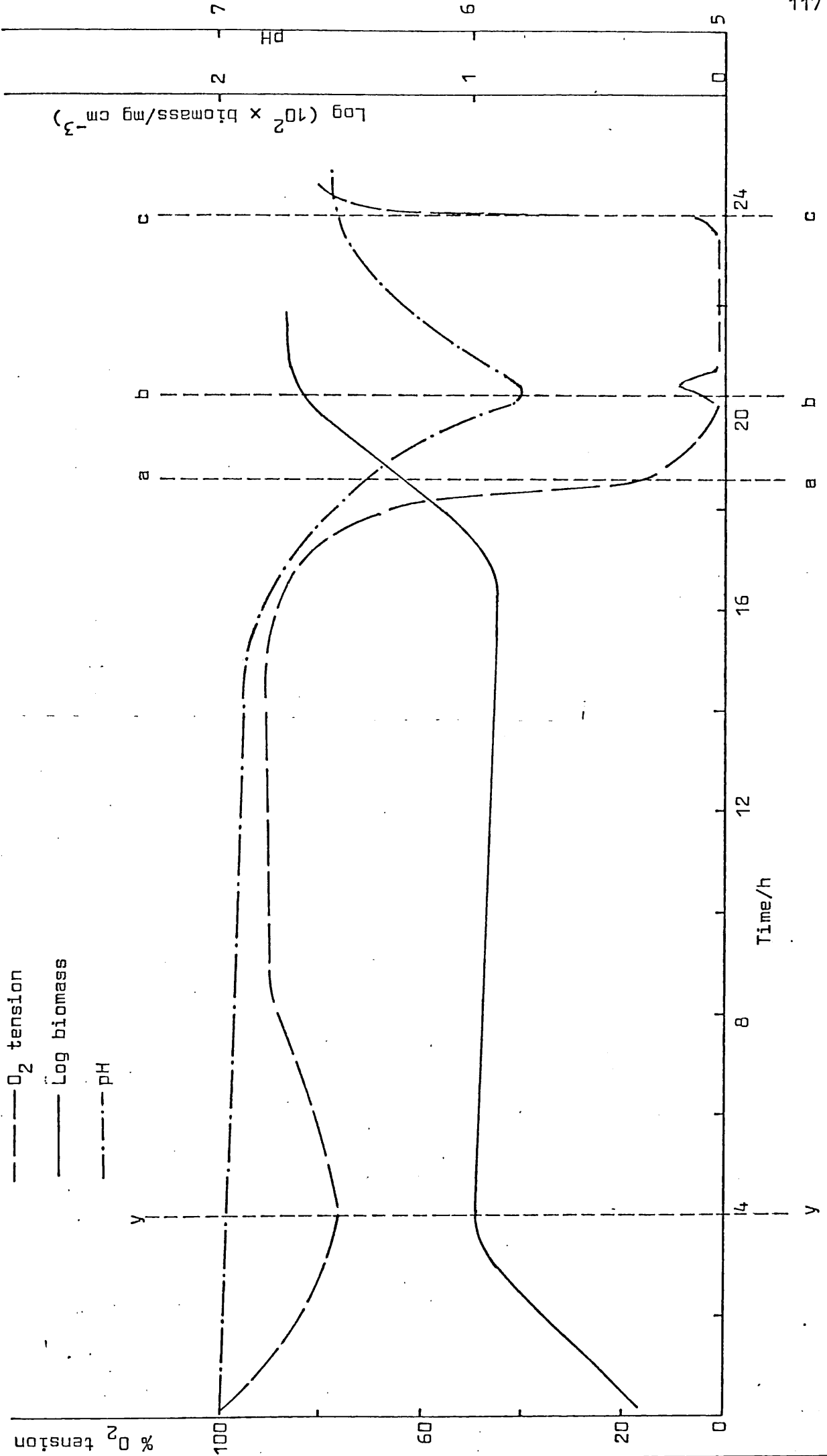

Table 4.5

Heat evolved and associated properties during the growth of

cells of K. aerogenes in the presence of nalidixic acid

Concentration / $\mu\text{g cm}^{-3}$	Heat evolved/J				Biomass/ mg cm^{-3}						
	mg/min	O-yy	O-el*	el-aa**	aa-bb	bb-cc	Total	yy	aa	bb	Min pH
0 (Control)	38	-	-	1.1	3.8	9.6	14.5	-	0.13	0.46	5.45
3	40	-	-	1.2	3.7	9.4	14.3	-	0.14	0.46	5.5
30	70	1.4	4.4	1.8	3.0	4.4	13.6	0.1	0.19	0.45	5.8
42	78	1.4	5.4	1.9	2.3	3.7	13.3	0.1	0.19	0.45	5.8

* From inoculation to the end of the lag phase

** From the end of the lag phase to aa

gradually during the period of secondary metabolism, until cc, at which point the heat output fell sharply as the oxygen tension rose. The heat evolved between the end of the lag phase and aa was greater than that between inoculation and aa for drug-free growth. The heat evolved between aa and bb, and between bb and cc was significantly less for growth in the presence of the antibiotic. The minimum pH value was higher after growth in the presence of nalidixic acid. The nalidixic acid reduced the growth rate; the mgt was 70 minutes and the stationary phase was reached about 16 h after inoculation. The biomass at aa was higher than for growth in drug-free medium but the biomass at bb was the same as for drug-free growth.

The growth of cells at a concentration of $42 \mu\text{g cm}^{-3}$ of nalidixic acid followed the same pattern of changes in growth, heat output, pH changes etc.. However, the time to the onset of the lag phase was reduced (to 4 h after inoculation) during growth at the higher concentration, whilst the length of the lag phase was increased (to about 12 h) and the end of the exponential growth phase (bb) was delayed (to about 20 h after inoculation). The mgt was increased to 78 minutes but the biomass at yy, aa and bb was the same as for growth at the lower concentration. The minimum pH value was the same for growth at both concentrations. Also, the heat evolved from inoculation to yy, from the end of the lag phase to aa and the total heat was the same as during growth in $30 \mu\text{g cm}^{-3}$ of nalidixic acid. The total heat evolved from inoculation to the end of the lag phase was greater in the higher concentration, whilst the heat evolved between aa and bb, and between bb and cc was slightly less at $42 \mu\text{g cm}^{-3}$.

At a still higher concentration of nalidixic acid ($60 \mu\text{g cm}^{-3}$), after an initial period of slight growth, all further growth ceased up to a period of at least 45 h after inoculation.

Organisms isolated at the end of an experiment using $42 \mu\text{g cm}^{-3}$ of nalidixic acid, subsequently proved to have an MIC of nalidixic acid of $12 \mu\text{g cm}^{-3}$, a barely significant increase compared with the original value of $6 \mu\text{g cm}^{-3}$.

4.6 Growth of cells of *K. aerogenes* in the presence of sulphanimide

Cells of *K. aerogenes* were grown in synthetic medium in the presence of 200, 800 and $1200 \mu\text{g cm}^{-3}$ of sulphanimide. At these concentrations there was no appreciable lag phase before growth. The results are summarised in Table 4.6 and the results for growth at $1200 \mu\text{g cm}^{-3}$ shown in Figure 4.6.

The nature of the thermogram was markedly altered by the presence of the drug at all concentrations used, compared with drug-free growth. The heat output increased after inoculation until aa and then subsequently increased more slowly until the onset of the stationary phase at bb. The heat output fell rapidly at bb, but instead of forming a plateau value as in drug-free growth, the heat output increased to a maximum value and then gradually fell away until cc, where it decreased rapidly as secondary metabolic processes ceased. The heat evolved between inoculation and aa was higher than for drug-free growth with 200 and $800 \mu\text{g cm}^{-3}$ of sulphanimide, but was lower for growth in $1200 \mu\text{g cm}^{-3}$ of sulphanimide. The

Figure 4.6 Untrained cells of *K. aerogenes* grown in the presence of sulphamileamide ($1200 \mu\text{g cm}^{-3}$)

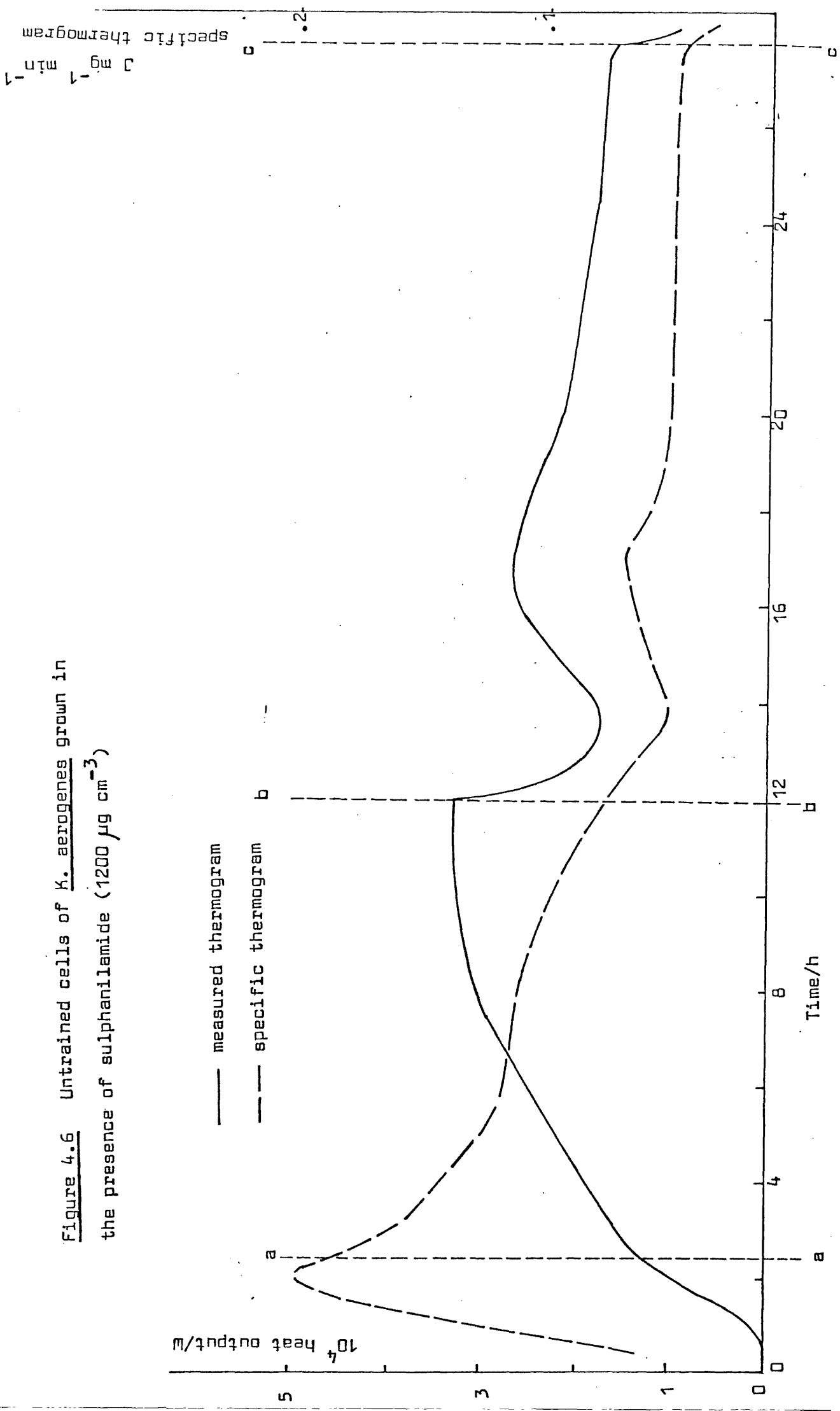

--- O₂ tension
 — Log biomass
 -.- pH

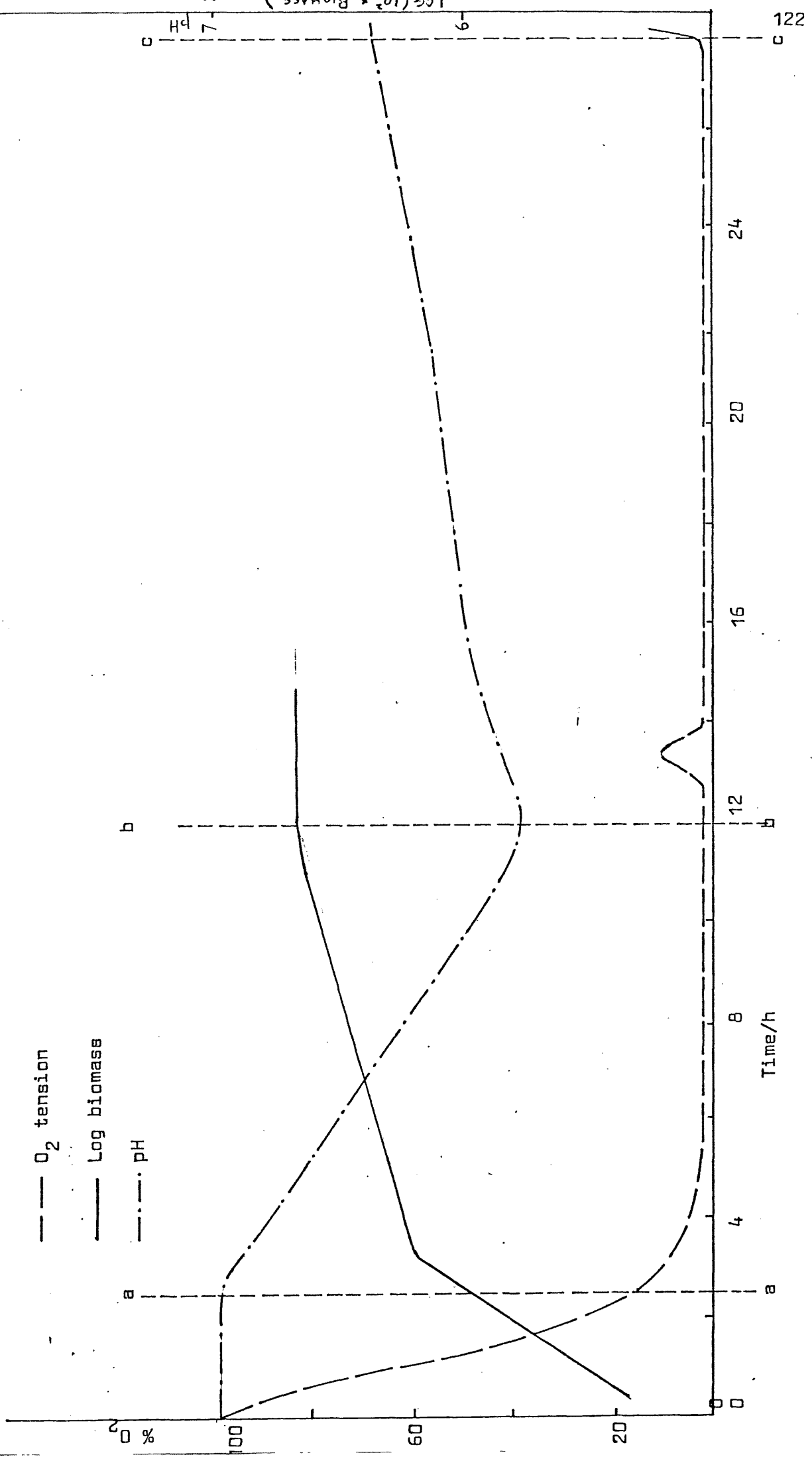

Table 4.6

Heat evolved and associated properties during the growth of cells of *K. aerogenes* in the presence of sulphanimide

Concentration $\mu\text{g cm}^{-3}$	mgt/min	Heat evolved/J				Biomass mg cm^{-3}		Min. pH
		0-aa	aa-bb	bb-cc	Total	aa	bb	
0 (Control)	38	1.1	3.8	9.6	14.5	0.13	0.46	5.45
200	42 73	1.6	4.5	8.5	14.5	0.12	0.45	5.7
800	48 84	1.5	5.0	8.1	14.6	0.13	0.44	5.7
1200	60 274	0.5	8.3	12.0	20.8	0.11	0.45	5.7
1200 (Trained cells)	75	1.3	3.8	9.2	14.3	0.13	0.47	5.65

heat evolved between aa and bb became greater with increasing concentrations of antibiotic. The heat evolved between bb and cc was slightly lower during growth in the presence of 200 and 800 $\mu\text{g cm}^{-3}$ of sulphanimide than for drug-free growth, but was higher for growth in the presence of 1200 $\mu\text{g cm}^{-3}$ of the drug. The total heat evolved during growth in the presence of 200 or 800 $\mu\text{g cm}^{-3}$ of sulphanimide was the same as for the control; at 1200 $\mu\text{g cm}^{-3}$ the total heat evolved was 50% higher.

The biomass at aa and at bb was unaffected by the presence of sulphanimide. The growth of cells of *K. aerogenes* in these

concentrations of sulphanilamide was biphasic, giving rise to two mgt values.

The minimum pH values for growth in the presence of different concentrations of sulphanilamide was 5.7, which was slightly higher than that during drug-free growth.

Cells were trained to grow in the presence of $1200 \mu\text{g cm}^{-3}$ of sulphanilamide and finally grown at this concentration. The thermogram and other environmental data were recorded (Table 4.6). The shape of the thermogram and other properties were similar to those of untrained cells grown in drug-free medium and no biphasic growth was observed. The growth rate was faster than that of untrained cells growing at this concentration of sulphanilamide, but it had not attained the value characteristic of control cells growing in drug-free medium. The total heat evolved was less than that of untrained cells growing in the presence of the drug at this concentration and was comparable to that of control cells.

4.7 Growth of Cells of *K. aerogenes* in the Presence of Proflavine

Cells of *K. aerogenes* were grown in synthetic medium containing $25 \mu\text{g cm}^{-3}$ ($\frac{1}{2}$ x MIC) of proflavine. The results are shown in Figure 4.7 and summarised in Table 4.7.

After inoculation, an initial increase in heat output and a decrease in oxygen tension was detected. This period was followed by a lag phase where biomass, heat output and oxygen tension remained constant. The heat output increased with the

Figure 4.7 Untrained cells of *K. aerogenes* grown

in the presence of proflavine ($25 \mu\text{g cm}^{-3}$)

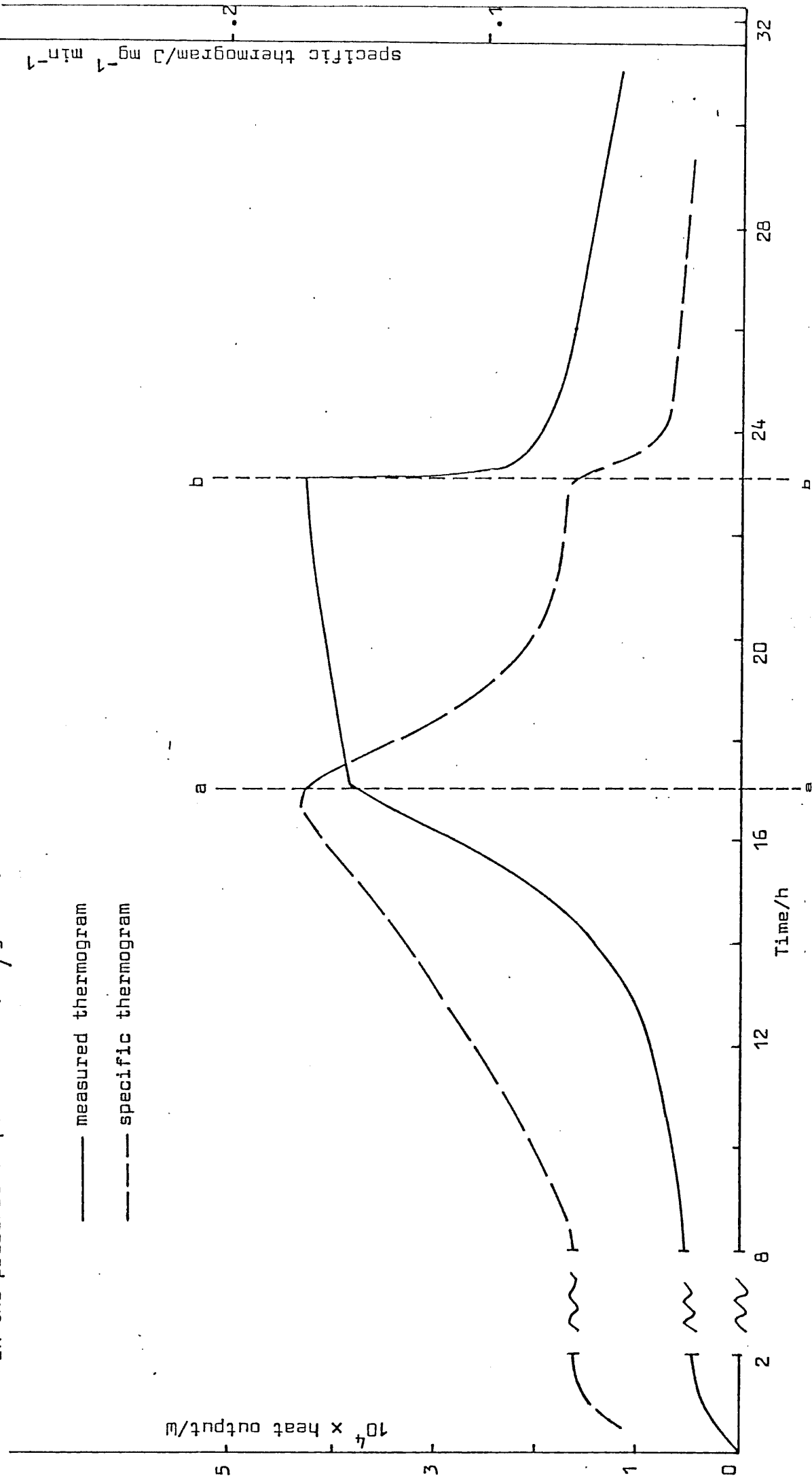

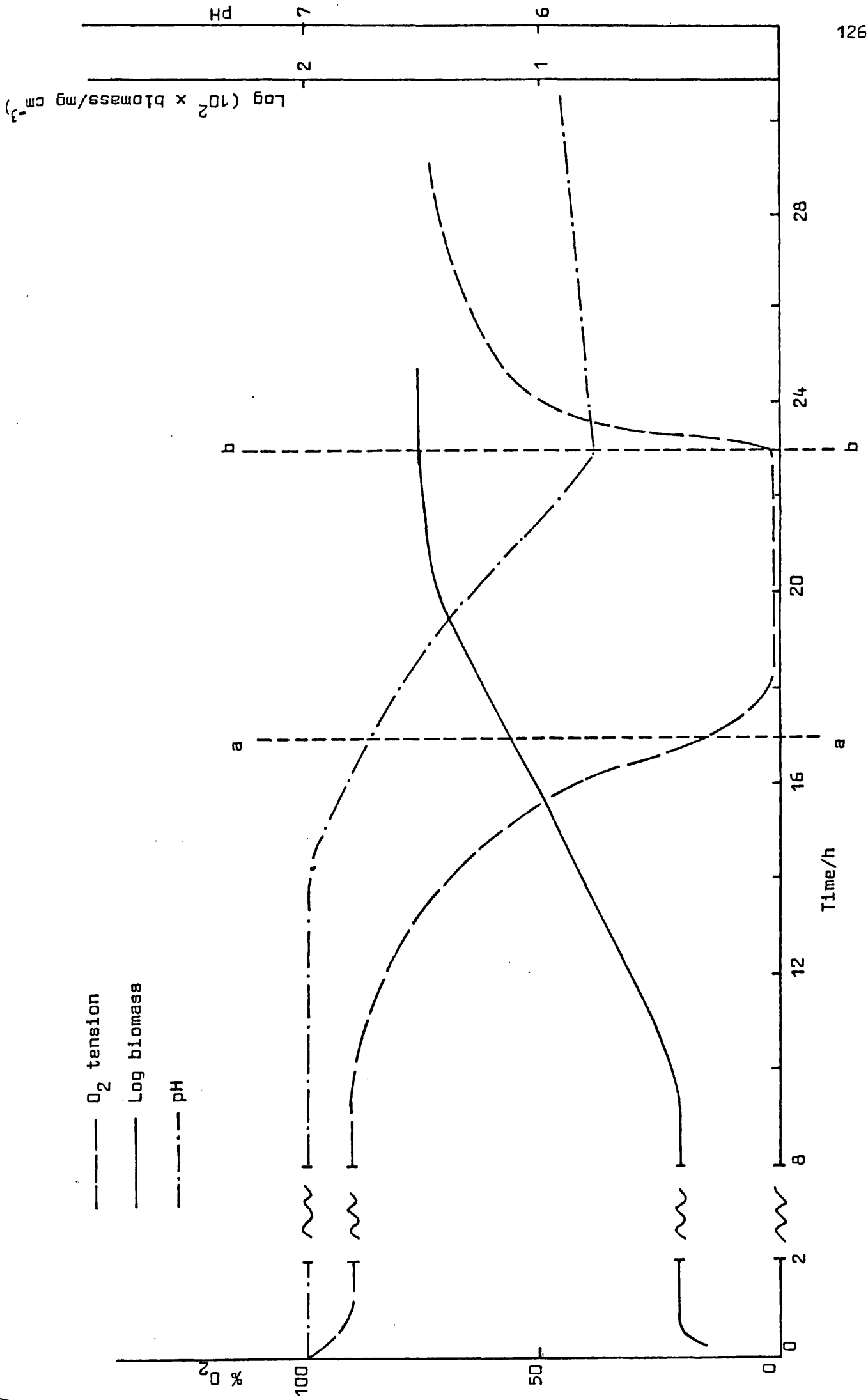

Table 4.7

Heat evolved and associated properties during the growth of
cells of K. aerogenes in the presence of proflavine

Concentration / $\mu\text{g cm}^{-3}$	mgt/min	Heat evolved/J				Biomass /mg cm^{-3}		Min pH
		0-aa	aa-bb	bb-cc	Total	aa	bb	
0 (Control)	38	1.1	3.8	9.6	14.5	0.13	0.46	5.45
25	144	5.2	8.7	0*	13.9	0.13	0.33	5.8
25 (Trained cells)	75	1.1	4.5	8.6	14.2	0.12	0.46	5.75

* Due to the absence of the region bb-cc

onset of the exponential growth phase, the rate of increase decreasing markedly at aa (similar to the control). At the beginning of the stationary phase, bb, the heat output fell sharply to a low value of about 2×10^{-4} W (Figure 4.7). This considerable heat output then decreased slowly but smoothly to a lower value ($\sim 1 \times 10^{-4}$ W), over a period of 11 h. No plateau value (bb-cc) of heat output was observed, as was obtained for control cells. At bb the oxygen tension rose rapidly, indicating the absence of aerobic metabolic processes after bb. Correspondingly the pH only increased slightly after bb as compared to growth in drug-free medium and it thus appears that in the absence of secondary metabolic processes, the acidic products accumulated. The cells took 23 h to reach the

stationary phase, and the mgt was 144 minutes, compared to 38 minutes in drug-free medium. The total heat evolved between inoculation and bb (where the oxygen tension rose) was not significantly different from the total heat evolved by cells grown in drug-free medium. However, in the absence of the region between bb and cc, the heat evolved between inoculation and aa, and between aa and bb was greater than the corresponding heat evolution for drug-free growth. The large evolution of heat after bb in the presence of the drug was presumably due to endogenous metabolism. The biomass (0.33 mg cm^{-3}) at bb was reduced by the presence of the drug, whilst the biomass at aa (0.13 mg cm^{-3}) was unaffected.

Cells were trained to grow at a proflavine concentration of $25 \mu\text{g cm}^{-3}$. When these cells were finally grown in the presence of this concentration of the drug, the thermogram and related environmental data were similar to those of untrained cells grown in the absence of the drug. The phase of secondary metabolism between bb and cc was now present. A short lag phase (about 30 minutes) followed inoculation and this was in turn followed by exponential growth. The mgt was 75 minutes and the onset of the stationary phase occurred after about 7 h. The total heat evolved was the same as for untrained cells grown in drug-free medium.

4.8 Summary

- (a) Irrespective of the presence of any concentration of any of the antibacterial agents used, the following points of similarity are evident:

- (i) at an oxygen tension of 15% the biomass is 0.11-0.19 mg cm⁻³;
 - (ii) complete oxygen depletion always occurs before the onset of the stationary phase;
 - (iii) glucose is exhausted at the onset of the stationary phase;
 - (iv) the pH always decreases to a minimum value at the onset of the stationary phase, and with the exception of proflavine the pH increases during secondary metabolism to a value only slightly less than the initial value;
 - (v) there is a small heat output during the late lag phase;
 - (vi) with the exceptions of sulphanimide and proflavine (and gentamicin and nalidixic acid at high concentrations), the general shape of the thermograms once growth commences is very similar to that exhibited by control cells.
- (b) The total heat evolved during growth in high concentrations of penicillin, methicillin and carbenicillin is less than that evolved during the growth of control cells; in contrast, the total heat evolved during growth in high concentrations of gentamicin and sulphanimide is greater.
- (c) The heat evolved by cells with in vitro resistance to penicillin, gentamicin, proflavine and sulphanimide is the same as for control cells.

CHAPTER 5

GROWTH OF CELLS OF P. AERUGINOSA IN THE

PRESENCE AND ABSENCE OF GENTAMICIN

The experiments described in this chapter are a preliminary examination of the effects of gentamicin on the growth of a number of gentamicin-sensitive and gentamicin-resistant strains of P. aeruginosa.

5.1 MIC of Gentamicin Values

The MIC of gentamicin values for growth in synthetic medium of the four strains of P. aeruginosa used in this study are listed in Table 5.1.

Table 5.1

MIC of gentamicin of strains of P. aeruginosa
during growth in synthetic medium and nutrient broth

Strain	MIC of gentamicin/ $\mu\text{g cm}^{-3}$ during growth in:	
	Synthetic medium	Nutrient broth
1	0.05	0.1
100	2000	8000
104	250	1250
Capetown no. 18	25	100

Gentamicin-resistance is enhanced by the presence of calcium and magnesium cations in the growth medium (Zimelis and Jackson, 1971). The low content of these cations in the synthetic

medium resulted in lower MIC values during growth in this medium than the corresponding values for growth in nutrient broth.

MIC values less than or equal to $12 \mu\text{g cm}^{-3}$ are defined as gentamicin-sensitive and those greater than $12 \mu\text{g cm}^{-3}$ as resistant. Strain 1 is thus a gentamicin-sensitive strain, whilst strains 100 and 104 are both highly resistant strains which do not possess transmissible *R*-factors mediating resistance to gentamicin (Chapman and James, 1977). Cells of Capetown no. 18 possess *R*-factors mediating gentamicin-resistance by means of an acetylating enzyme (Jacoby, 1974).

5.2 Growth of Cells of Strains of *P. aeruginosa* in Drug-Free Medium

The thermograms and other physical properties for the growth of the four strains of *P. aeruginosa* at 37°C in synthetic medium are shown in Figures 5.1, 5.2, 5.3 and 5.4. The results are summarised in Table 5.2.

The most convenient method of considering the thermograms is to divide the strains according to their resistance to gentamicin.

(i) Strain 1 - sensitive (Figure 5.1).

The smooth increase in heat output during growth reflected the decrease in oxygen tension of the culture; the heat output continued to increase, albeit at a reduced rate after oxygen exhaustion, attaining a maximum value at pp, 13 h after inoculation. The heat output decreased rapidly to qq, to about 80% of the maximum value, where it remained constant for about

Figure 5.1 P.aeruginosa strain 1 grown in
drug-free medium

— . — . — . — pH
— — — — — O₂ tension
————— measured thermogram
— ● — ● — glucose (% initial concn)

Glucose (% initial concn)

O₂ tension, 60 20

pH

7 6

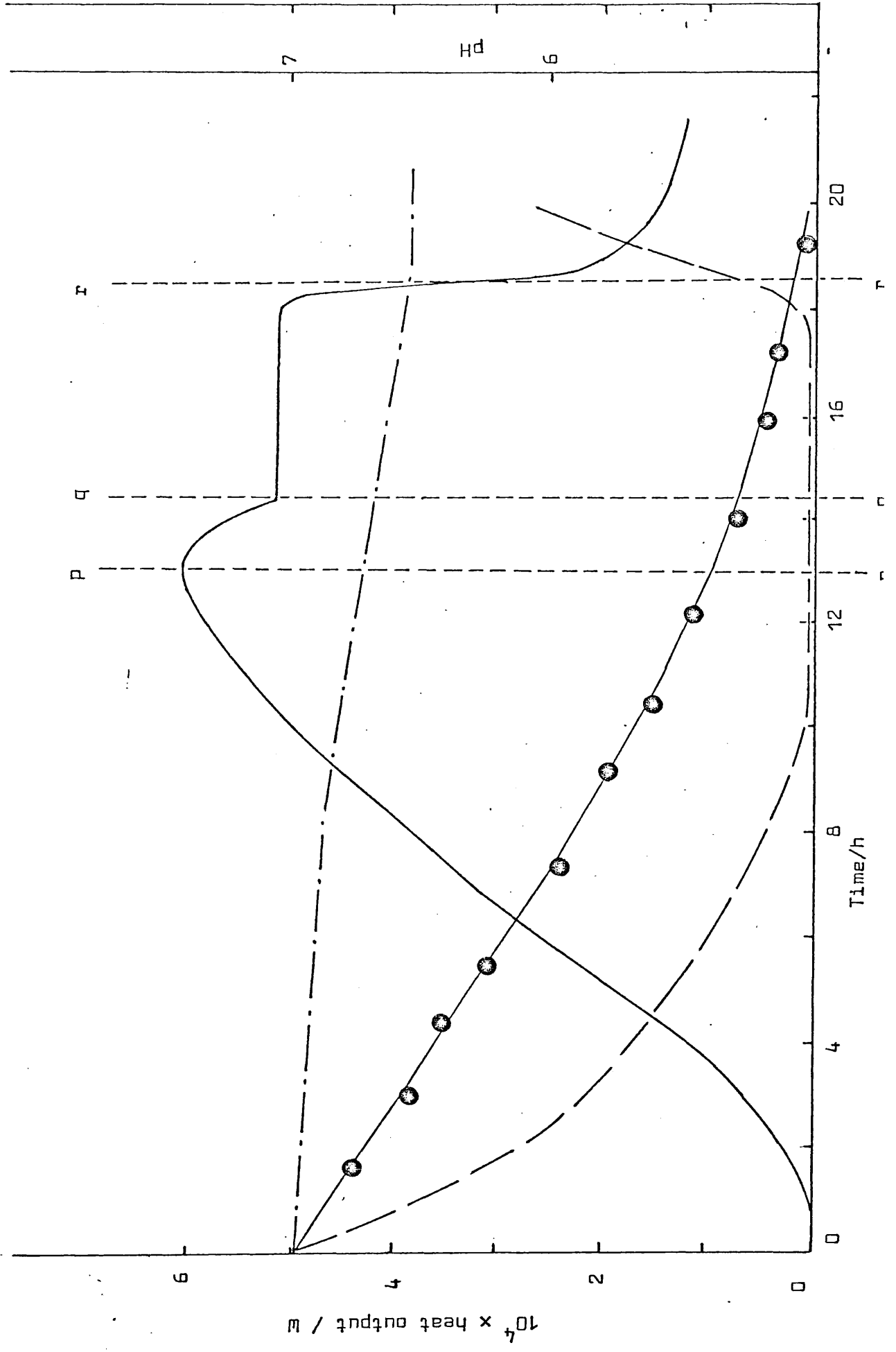

Table 5.2

Heat evolved and associated properties during the growth of cells of strains of *P. aeruginosa* in the presence of gentamicin

Strain	Heat evolved/J							
	Inoc. to qq			qq to rr			Total	
	d.f.	gm	% change	d.f.	gm	% change	d.f.*	gm**
1	14.3	17.1	19	8.2	3.4	58	22.5	20.5
100	10.7	13.9	29	3.8	0	100	14.5	13.9
104	13.5	16.3	20	3.8	1.8	52	17.3	18.1
Capetown	14.9	18.9	27	0	0	0	14.9	18.9

* Drug-free growth

** Growth in the presence of gentamicin

4 h. There was then a marked and sudden decrease, rr, in the heat output, accompanying an increase in the oxygen tension. In contrast to similar studies with *K. aerogenes* the glucose was not depleted until after the oxygen tension increased, and although the pH of the medium decreased it never increased as a result of secondary metabolism of acidic products.

(ii) Strains 100 and 104 - resistant (Figures 5.2 and 5.3).

The general pattern of heat output was as for cells of strain 1, attaining a maximum value at pp. The decrease in heat output

Figure 5.2 P. aeruginosa strain 100 grown in
drug-free medium

— · — · — · pH

— — — — O₂ tension

————— measured thermogram

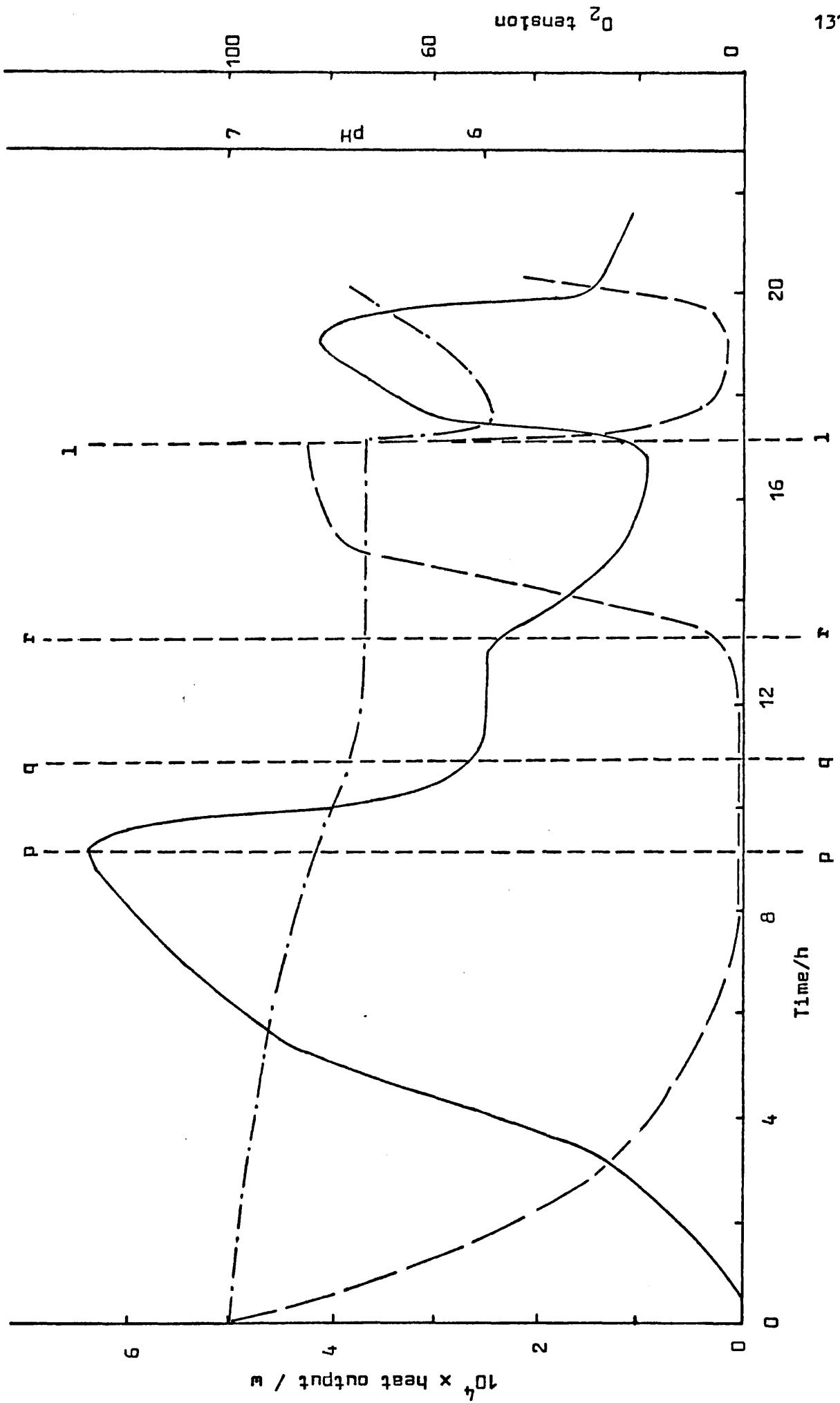
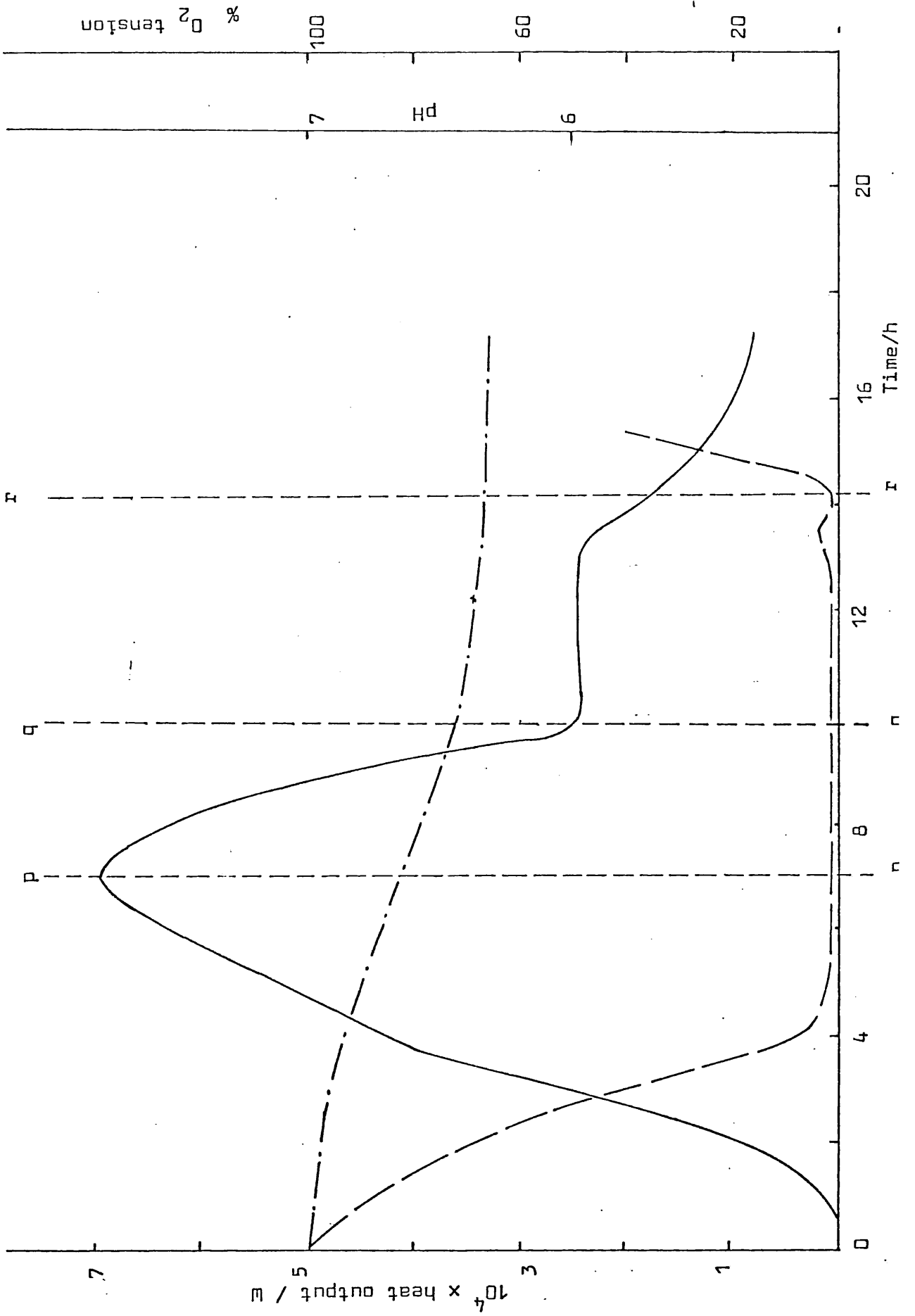

Figure 5.3 *P. aeruginosa* strain 104 grown in
drug-free medium

..... pH
----- O₂ tension
_____ measured thermogram



from pp to qq was more marked than for strain 1 and the plateau value was only about 40% of the maximum. The sudden decrease in heat output, rr, accompanied an increase in the oxygen tension.

- (iii) Strain Capetown no. 18 - R-factor mediated resistance (Figure 5.4).

The increase in heat output to a maximum at pp was followed by a dramatic decrease to a value of about 20% of the maximum output, which occurred at the same time as the oxygen tension increased. There was no detectable plateau region (qq to rr).

The total heat evolved was greatest during the growth of cells of the sensitive strain (Table 5.2).

Due to the clumping of the bacterial cells of all four strains growing in this medium, the absorbance and hence biomass of the culture could not be determined with any great accuracy. For this reason the growth curves and specific thermograms are not plotted. Absorbance readings which were taken indicated that rr corresponded to the onset of the stationary phase (approximate biomass of 0.4 mg cm^{-3} for all four strains).

The strains of P. aeruginosa grew more slowly than did the K. aerogenes strain. Strain 1 took 18 h from inoculation to reach the stationary phase, strains 100 and 104, 14 h, and strain Capetown no. 18, 12 h.

There was no evidence of secondary metabolism of acidic fermentation products such as occurred with cells of K. aerogenes. Thus the pH value remained at a low value (~ 6.5) after the onset of the stationary phase. When acetic acid was added (at 11, Figure 5.2)

Figure 5.4 P. aeruginosa strain Capetown no. 18
grown in drug-free medium

..... pH
----- O₂ tension
----- measured thermogram

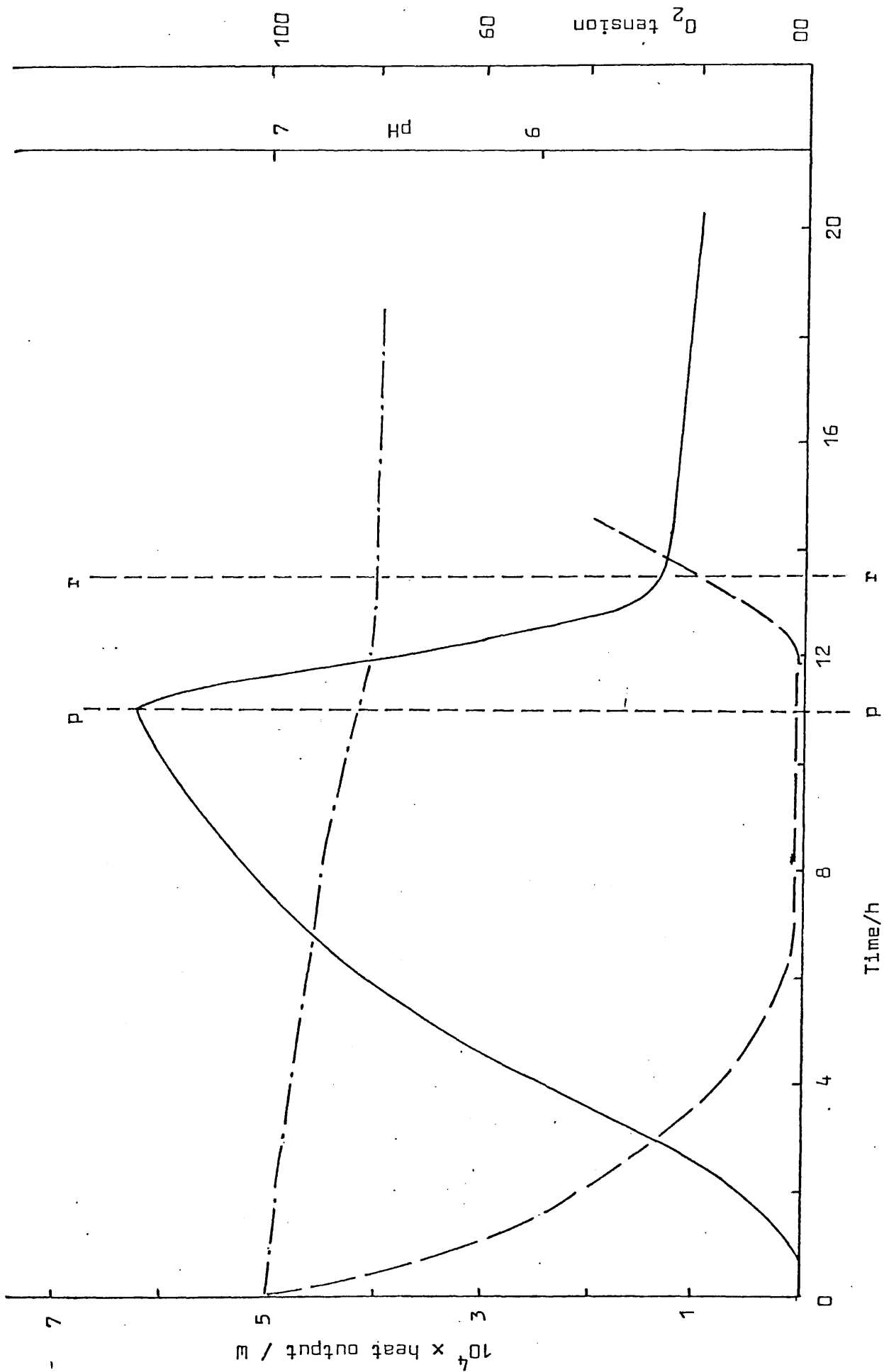

to stationary phase cultures, evidence of ensuing metabolism was obtained, the pH value rising at the same time as a large heat output was detected. The absence of such changes of pH during normal growth suggests that the strains did not produce acetic acid.

5.3 Growth of Cells of Strains of *P. aeruginosa* in the Presence of Gentamicin

P. aeruginosa strains 1, 100, 104 and Capetown no.18 were grown in synthetic medium containing a fixed relative concentration of 4 x MIC of gentamicin. Thus strain 1 was grown at a concentration of $0.2 \mu\text{g cm}^{-3}$, strain 100 at $8000 \mu\text{g cm}^{-3}$, strain 104 at $1000 \mu\text{g cm}^{-3}$ and strain Capetown no. 18 at $100 \mu\text{g cm}^{-3}$. The results of thermograms and other environmental data are shown in Figures 5.5, 5.6, 5.7 and 5.8. The results are summarised in Table 5.2.

Cells of strains 1 and 104 both showed a slight initial heat output and reduced oxygen tension when inoculated into the medium containing gentamicin, presumably due to slight growth. However, the heat output soon returned to its original value, whilst the oxygen tension rose to almost its original value. A lag phase then followed (until 22 and 24 h after inoculation for strains 1 and 104 respectively), during which time no growth was observed, and the heat output, oxygen tension, pH, biomass and glucose concentration all remained constant. Cells of the other two strains, 100 and Capetown no. 18, exhibited a short lag phase (~ 1 h for each strain) immediately after inoculation. No large heat output was observed during these lag phases as was observed with cells of

Figure 5.5 P. aeruginosa strain 1 grown in the presence
of gentamicin

---:---: pH
---:---: O₂ tension
---:---: measured thermogram

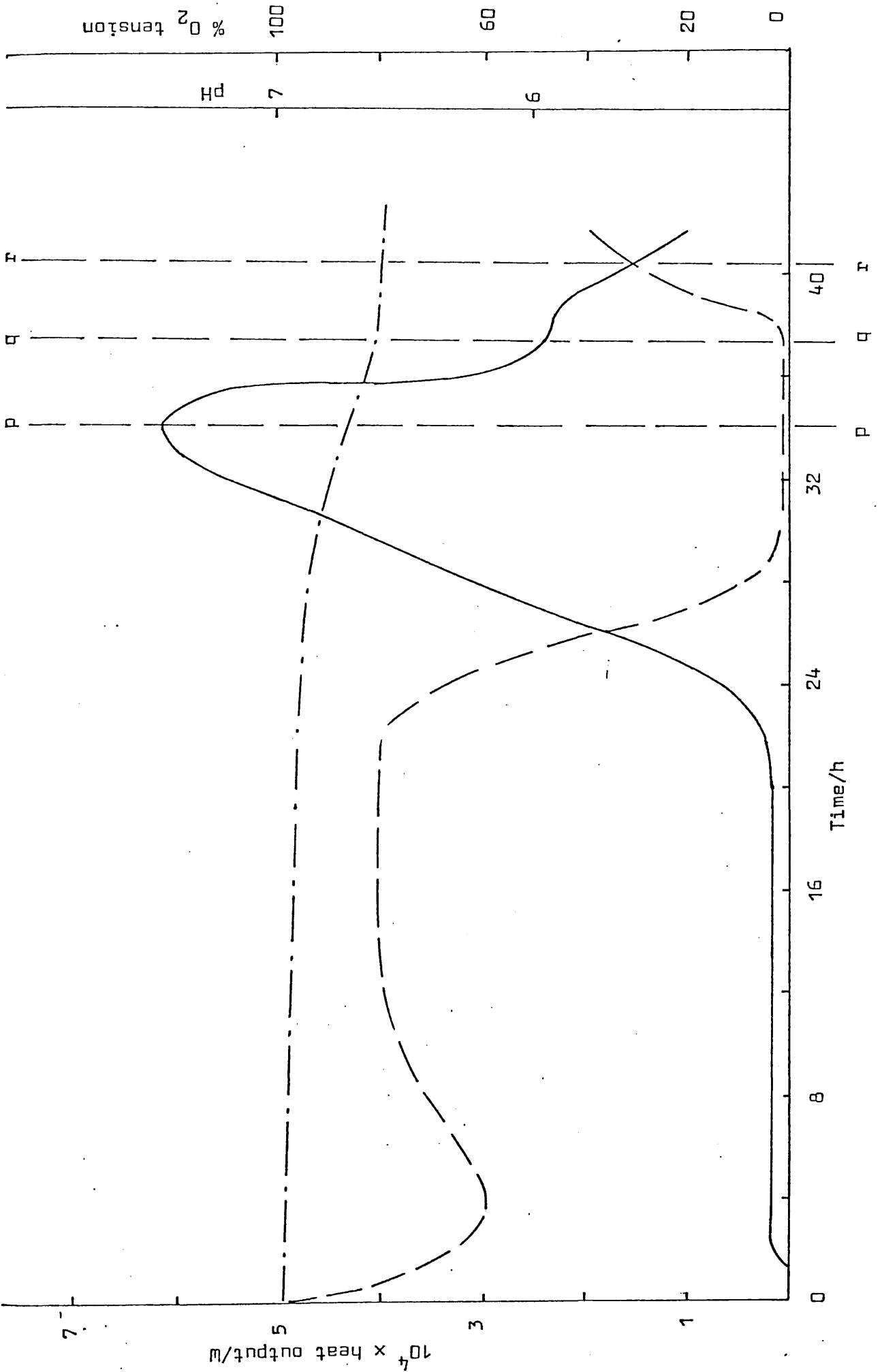

Figure 5.6 P. aeruginosa strain 100 grown in the presence
of gentamicin

----- pH

----- O₂ tension

----- measured thermogram

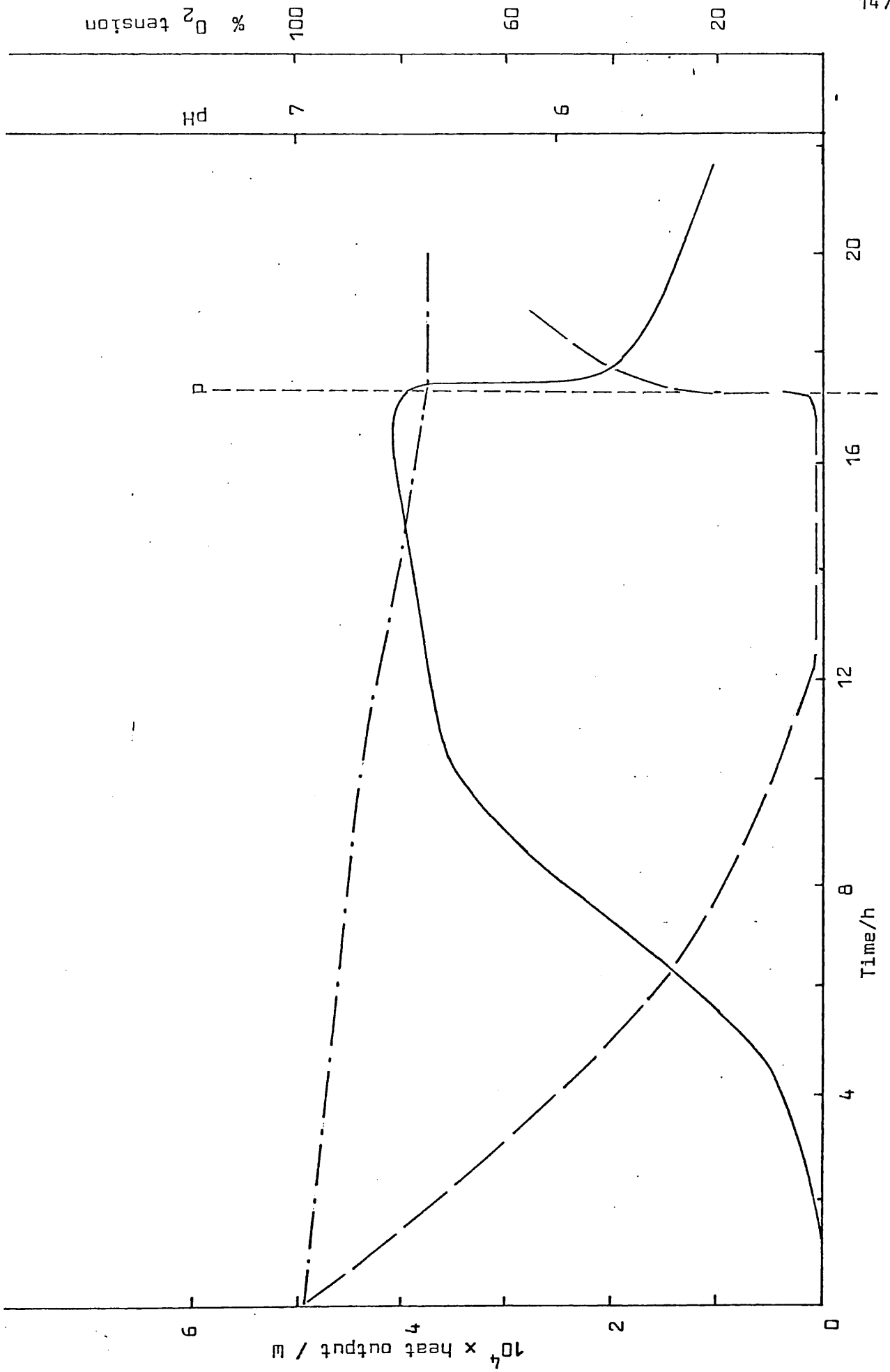

Figure 5.7 P. aeruginosa strain 104 grown in the presence
of gentamicin

..... pH

----- O₂ tension

_____ measured thermogram

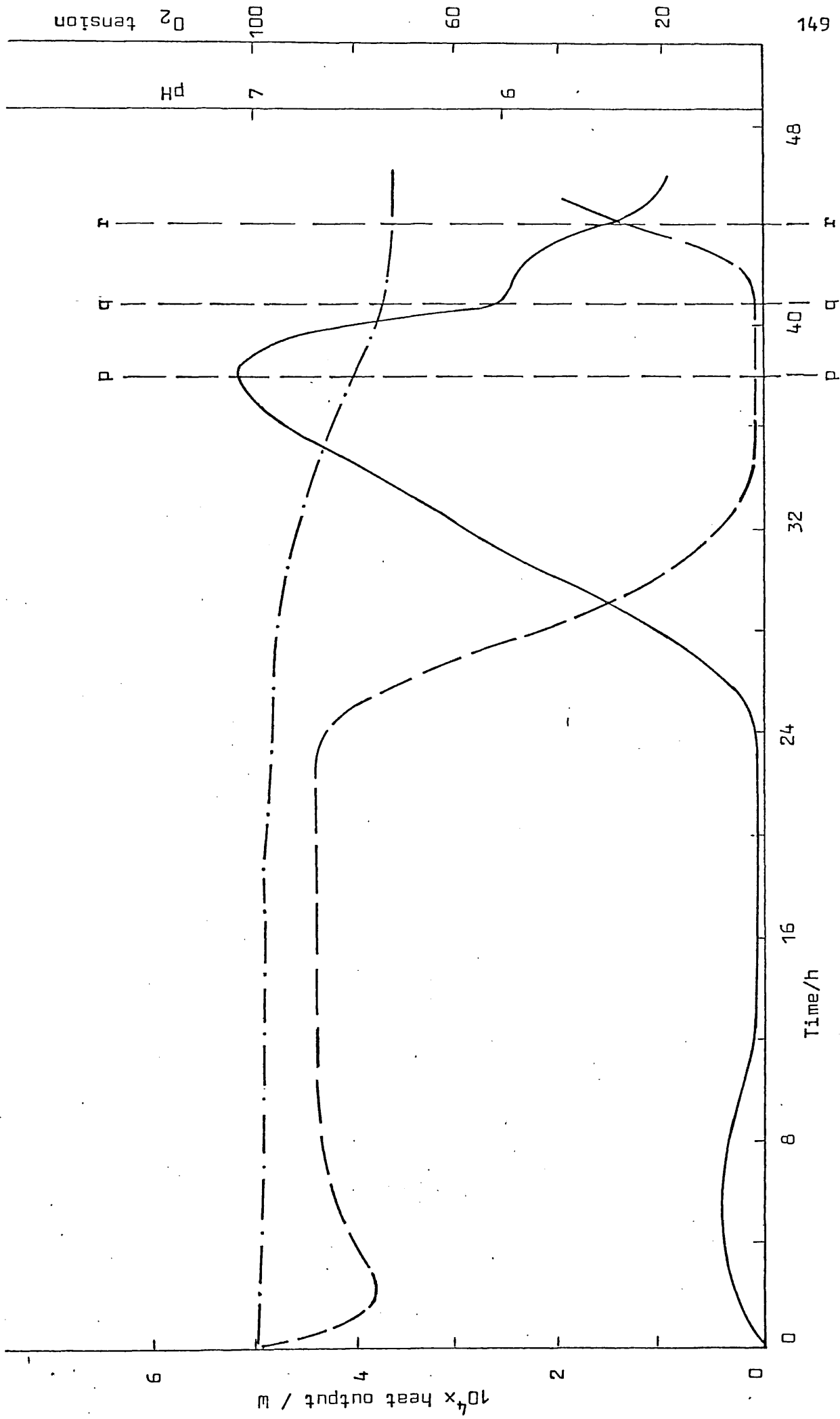
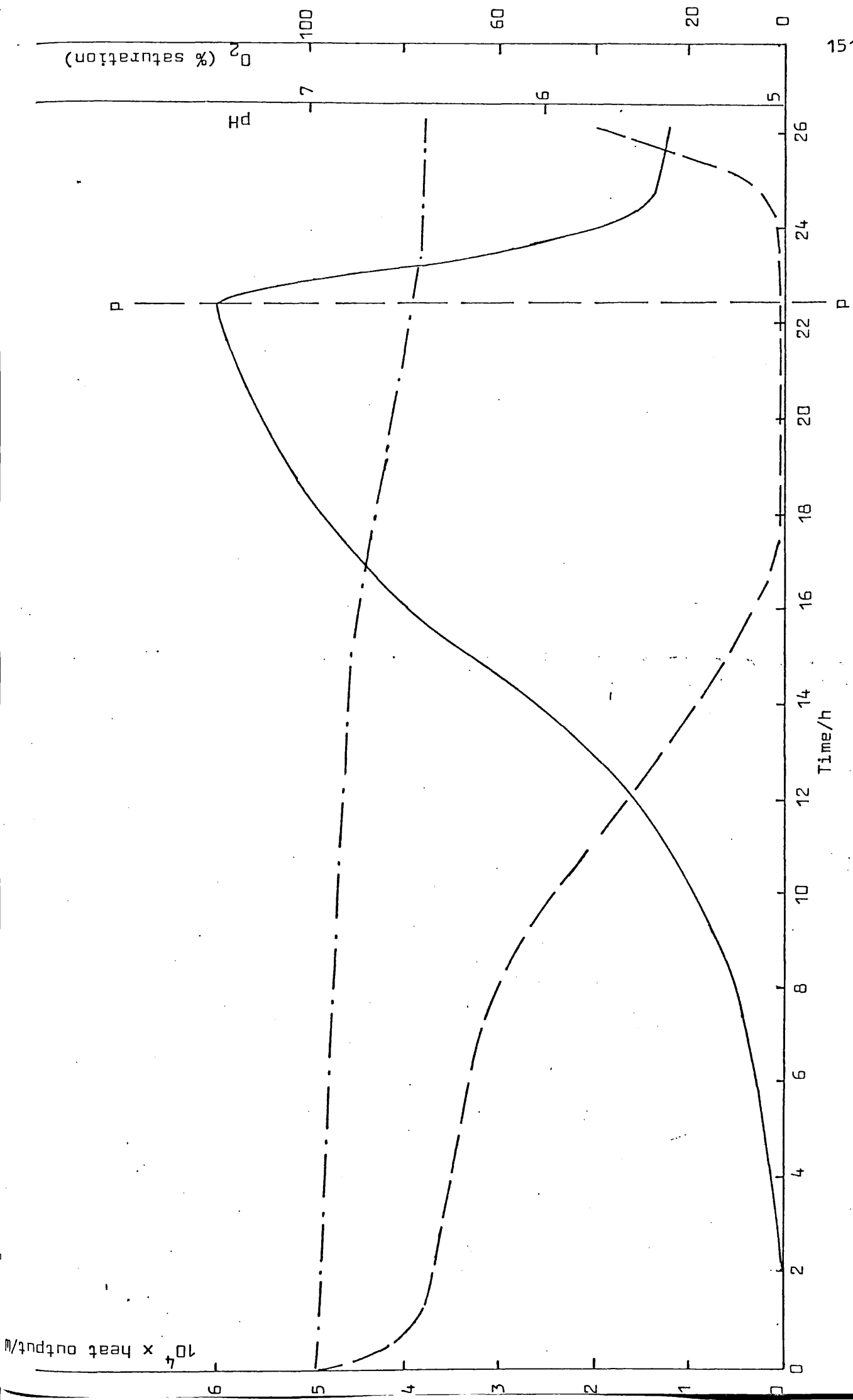

Figure 5.8 P. aeruginosa strain Capetown no. 18
grown in the presence of gentamicin

----- pH
----- O₂ tension
----- measured thermogram



K. aerogenes growing in the presence of a corresponding concentration of gentamicin.

At the end of the lag phase all the strains entered the phase of exponential growth and grew until the point of maximum heat output (pp). For cells of strains 1 and 104 the heat output then fell rapidly to give a plateau value (about 40 to 50% of the maximum value), which then fell to a low value when there was an increase in oxygen tension, as for drug-free growth. The heat output of cells of strain Capetown no. 18 fell rapidly to give a low value at the same time as the oxygen tension increased. This represented the onset of the stationary phase, again as for drug-free growth. The heat output of cells of strain 100 however, fell sharply to give a low value, without exhibiting a plateau value as they had during drug-free growth. This marked decrease in heat output accompanied an increase in the oxygen tension.

The heat evolved by cells of all four strains from inoculation to qq was considerably greater (20 to 30%) during growth in the presence of corresponding concentrations of the antibiotic, compared with growth in drug-free medium. The heat evolved between qq and rr (i.e. the point at which oxygen tension increased) was markedly lower than that for drug-free growth, for strains 1 and 104. The total heat evolved was unchanged by growth in the presence of gentamicin for cells of strains 1, 100 and 104. The total heat evolved during growth in the presence of gentamicin was considerably higher for cells of strain Capetown no. 18 (Table 5.2) compared with that evolved during drug-free growth

5.4 Batch Calorimetry

Batch calorimetry was used to detect any interaction occurring between 3 cm³ of cells of K. aerogenes (biomass .08 mg cm⁻³) suspended in water (Section 4.4) or of P. aeruginosa strains 1, 100 and Capetown no. 18 suspended in medium and 1.5 cm³ of gentamicin solution. At a final concentration of 5 µg cm⁻³ of gentamicin there was no detectable heat evolved. A small exothermic reaction was detected at a gentamicin concentration of 50 µg cm⁻³ for all the strains. The results are shown in Table 5.3.

Table 5.3

Heat evolved during the interaction of bacterial cells with gentamicin (final gentamicin concentration of 50 µg cm⁻³)

<u>Strain</u>	<u>MIC of gentamicin /µg cm⁻³</u>	<u>Heat evolved x 10⁴ J /mg bacteria/µg gentamicin</u>
<u>P. aeruginosa</u>		
1	0.05	2.4
100	2000	0.1
Capetown no. 18	25	4.5
<u>K. aerogenes</u>	0.05	4.9

5.5 Summary

- (a) The shape and position of the thermograms of cells of P. aeruginosa growing in drug-free medium depended on the resistance of the cells to gentamicin. In general the heat output increased during growth and then decreased, sometimes to a plateau value. The heat output reflected the oxygen tension of the medium.
- (b) The shape and position of the cells of the strains of P. aeruginosa grown in the presence of a corresponding concentration of gentamicin, showed some general similarities to those of cells grown in drug-free medium (except strain 100 for which the shape of the thermogram was somewhat altered).
- (c) The total heat evolved for the sensitive and two of the resistant strains was independent of the presence or absence of gentamicin. The heat evolved by cells of the R-factor mediated resistant strain was greater during growth in the presence of gentamicin.
- (d) Batch-cell calorimetry indicated a small exothermic interaction between gentamicin molecules and cells of strains of P. aeruginosa and K. aerogenes.

CHAPTER 6

CHEMICAL ANALYSIS OF WHOLE CELLS OF

STRAINS OF P. AERUGINOSA

6.1 Lipid content of cells of *P. aeruginosa*6.1.(a) Total lipid extracted

The total lipid contents of cells of the five strains of *P. aeruginosa*, determined by extraction with chloroform/methanol mixture (Section 2.3.(c)(i)), are shown in Table 6.1. Within the limits of experimental error, the amount of total lipid in these strains was constant, irrespective of their level of resistance to gentamicin. Good agreement was obtained between duplicate results for each strain.

Table 6.1Total lipid extracted from cells of *P. aeruginosa**

Strain	MIC of gentamicin/ $\mu\text{g cm}^{-3}$	% lipid**
1	0.1	10.0
1A/20	25	10.2
107	25	10.7
104	1250	10.8
100	8000	10.2

* These results are for cells grown in nutrient broth.

Indistinguishable results were obtained for cells grown on nutrient agar.

** Expressed as % dry cell weight

6.1.(b) Analysis of extracted lipid

The lipid components separated using thin-layer chromatography, were identified as described in Section 2.2.(c)(ii). Three solvent systems and six locating agents were used in analysing the lipid, since with an obvious difference in polarity between the two lipid classes i.e. phospholipid and neutral lipid, full resolution of components using a single solvent system would be difficult. Phospholipids (but not neutral lipids) were fully separated into individual components using the relatively polar solvent system (1). More complete analysis of neutral lipids was obtained using solvent system (3). The results are listed in Table 6.2. These results are for cells grown in nutrient broth; similar results were obtained when the cells were grown on agar. There was good agreement between duplicate results for each strain for each medium.

Irrespective of their level of resistance to gentamicin, cells of all the strains analysed possessed the same lipid components. The phospholipids were phosphatidyl ethanolamine and cardiolipin, and the neutral lipids were tripalmitin, palmitic acid and 1,3-distearin plus unidentified monoglycerides. The relative abundance of neutral and phospholipid (measured using a microdensitometer) showed close agreement between strains 1, 1A/20, 104 and 107 (Table 6.2). However, the very highly gentamicin-resistant strain 100 had a significantly higher proportion of neutral lipid and a lower proportion of phospholipid than these other strains.

Table 6.2Lipid extracted from cells of P. aeruginosa

	<u>Strain</u>				
	1	1A/20	107	104	100
Resistance to gentamicin *	S	IR	R	R	R
% phospholipid	62	65	62	65	52
% neutral lipid	38	35	38	35	48
S value **	0	-	10	25	17

* Gentamicin-sensitive (S), gentamicin-resistant (R) or induced gentamicin-resistant (IR)

** See Discussion

6.2 Amino acid content of cells of P. aeruginosa

The results of the amino acid analysis of cells grown in nutrient broth are shown in Table 6.3. Similar results were obtained when the cells were grown on agar. Duplicate results for each strain were in good agreement.

For each of the seventeen amino acids detected, there was a close agreement between the results for strains 1, 1A/20, 104 and 107. The amino acid content of cells of strain 100 was markedly lower for all amino acids than those of cells of the other strains.

Table 6.3Amino acid contents of cells of P. aeruginosa

Amino acid	<u>Strain</u>				
	1	1A/20	104	107	100
Alanine	0.84*	0.92*	0.96*	0.91*	0.63*
Glutamic acid	0.81	0.86	0.86	0.86	0.60
Glycine	0.81	0.81	0.83	0.81	0.71
Leucine	0.72	0.75	0.76	0.75	0.49
Aspartic acid	0.67	0.67	0.73	0.67	0.45
Valine	0.53	0.57	0.60	0.58	0.45
Lysine	0.48	0.46	0.46	0.50	0.38
Isoleucine	0.40	0.39	0.40	0.40	0.25
Arginine	0.38	0.38	0.39	0.40	0.25
Threonine	0.35	0.35	0.38	0.35	0.24
Proline	0.34	0.31	0.34	0.30	0.19
Serine	0.32	0.32	0.35	0.35	0.24
Phenylalanine	0.28	0.27	0.27	0.28	0.18
Cystine	0.22	0.25	0.27	0.25	0.16
Tyrosine	0.18	0.17	0.16	0.18	0.12
Histidine	0.14	0.16	0.15	0.16	0.07
Methionine	0.12	0.09	0.09	0.10	0.06

* Figures represent μmol of amino acid/mg of dry cell material

Glycine was the most abundant amino acid in cells of strain 100, whilst alanine was the most abundant amino acid in cells of the other four strains.

6.3 Analysis of protein, polysaccharide and nucleic acid content of cells of *P. aeruginosa*

The results obtained are listed in Table 6.4. For each strain, good agreement was obtained between duplicate determinations for each component.

Table 6.4
Protein, polysaccharide and nucleic acid contents of cells of *P. aeruginosa* grown in nutrient broth

Strain	Protein*	Polysaccharide*	DNA*	RNA*
1	76	3.0	5.3	8.5
1A/20	75	3.1	5.3	8.5
104	75	3.2	5.4	8.7
107	76	3.2	5.4	8.9
100	69	4.5	5.5	8.8

* Expressed as % dry cell weight

The DNA and RNA contents were very similar for cells of all five strains. However, whilst strains 1, 1A/20, 104 and 107 had similar polysaccharide contents, strain 100 had a significantly

higher polysaccharide content. Likewise, strain 100 differed from the other four strains in that it had a lower protein content. This is in agreement with the lower amino acid content of cells of this very resistant strain. It is thus apparent that (as with the differing lipid components) cells of the very highly gentamicin-resistant strain have a significantly different amino acid, protein and polysaccharide content from cells which are sensitive to gentamicin or which have lower levels of resistance.

6.4 Summary

- (a) The total lipid content of a number of gentamicin-resistant and gentamicin-sensitive P. aeruginosa strains was the same. The most highly resistant strain had a higher proportion of neutral lipid than the other strains.
- (b) The same very highly resistant strain had a markedly lower amino acid and protein content, and a higher polysaccharide content than the other strains. All the strains examined had the same DNA and RNA content.

CHAPTER 7

DISCUSSION

A conspicuous property of bacterial growth processes is the evolution of large quantities of heat; this is heat wasted and is a measure of the inefficiency of the metabolic processes. Calorimetry may be used to detect this heat evolution and thus gain information about the metabolic activities in progress. Prat (1963) employed sensitive modern calorimetric techniques in bacterial studies and showed that the behaviour of a microbial system is systematically reproducible and characteristic of the particular organism and medium. Whilst this work was essentially qualitative, later studies have demonstrated that the processes involved in bacterial metabolism can be investigated quantitatively using calorimetry (Battley, 1960; Forrest et al, 1961; Belaich, 1963; Boivinet, 1964).

In biological systems the chemical reactions may be considered to occur at constant volume and pressure. For such a system the thermodynamic differences between enthalpy and energy may be disregarded. Thus the energy change accompanying a reaction is equivalent to the change in enthalpy (ΔH) or heat of reaction. For an isolated system in which no external work is done, the calorimetrically measured heat evolution, Q , corresponds to the heat of reaction. Although it is the overall energy change which is detected during bacterial metabolism, in practice it has been found that a small number of simple reactions tend to predominate and thus have the major effect on the heat detected. It has also been shown that almost all the heat evolution produced by the metabolism of micro-organisms is a result of catabolic processes, with anabolic processes contributing relatively little (Morowitz, 1960; Boivinet,

1964; Senez and Beliach, 1965).

The technique of microcalorimetry may be used as a general method of characterizing microbial growth processes, having applications in the identification of micro-organisms (Boling et al, 1973; Monk and Wadsö, 1975; Russel et al, 1975) and in the testing of the susceptibility of bacteria to antibiotics (Binford et al, 1973). Mårdh et al, (1976) have used microcalorimetry to study the kinetics of the actions of different tetracyclines on a strain of E. coli. The results reported here represent a microcalorimetric study on the growth of bacteria in the presence of different antibiotics and antibacterial agents. In this type of investigation the use of a non-specific method has advantages over the determination of such quantities as the MIC, the normal method of studying the effects of antibiotics on bacteria. MIC determinations do not enable the kinetics of the action of antibiotics on bacterial cells to be studied, whereas microcalorimetry makes it possible to study events (i.e. changes in heat production) as they occur with time.

The organisms selected for microcalorimetric study were Klebsiella aerogenes and Pseudomonas aeruginosa. A parallel research project has used microcalorimetry to monitor the growth of cells of K. aerogenes in different glucose concentrations (Few et al, 1976). K. aerogenes was therefore chosen for the current study so that knowledge previously gained in this other cognate investigation, could be used in the interpretation of results obtained during growth in the presence of antibacterial agents. Strains of P. aeruginosa were employed to examine the heat changes accompanying the growth of gentamicin-sensitive and gentamicin-resistant cells both in the

absence and in the presence of gentamicin.

The method used to detect the heat output from growing bacterial cultures involves pumping the growing cells in the growth medium from the culture vessel into the calorimeter cell. This introduces the possibility of errors arising due to oxygen depletion in the tube and calorimeter cell. To help overcome this possibility, alternate portions of air and culture were pumped to the calorimeter. Under these conditions it was assumed that the cells in the calorimeter cell were at the same stage of growth as cells in the culture vessel. In spite of these precautions, oxygen depletion did occur in the calorimeter cell. However, as this rate-limiting effect occurred for all cultures, the results may be assumed to be comparable.

The rate of heat output, referred to as heat output, produced by a growing culture was determined from the rate of heat output by organisms in 1.2 cm^3 in the calorimeter cell. This heat output was detected and recorded as voltage changes (the difference in emf between thermopiles surrounding the measuring cell and the reference cell) with time. The range 0-100 mV was normally used. By suitable calibration, the voltage readings were converted into heat output expressed as W or J s^{-1} . At the end of an experiment, formalin was added to kill the bacteria in the culture vessel. This dead-cell suspension was aerated and pumped into the microcalorimeter cell at exactly the same rate as in the actual experiment. A known internal current was then applied for a known time to a resistance ($\sim 50 \Omega$) in the microcalorimeter cell block. The pulse so produced represents a known amount of heat and thus from this result a

calibration constant was calculated.

The total heat evolved, measured in joules, during the growth of a bacterial culture was obtained by integration of the area under the measured thermogram, and the result multiplied by the calibration constant. A computer programme in Fortran **IV** was used for this purpose. Again this represented the heat evolved by organisms in 1.2 cm^3 of culture in the calorimeter cell and not the actual heat evolved in the culture vessel.

The specific heat output, plotted as the specific thermogram, is a measure of the rate of heat evolved per unit biomass ($\text{J mg}^{-1} \text{ min}^{-1}$). It was calculated by integrating the heat output-time traces over short intervals (about 10 minutes) and dividing this by the biomass/mg in the calorimeter cell at the mid-point of the particular time interval. A computer programme was again used for this purpose. The use of specific thermograms is convenient in demonstrating the different rate of metabolic activity of cells at different times during the growth cycle. A disadvantage with their use is that errors may occur due to uncertainty in the measurement of biomass, especially at the start of growth when the cell population is small.

Biomass was obtained from the measured absorbance of the culture, using a calibration curve of dry weight against absorbance. This was constructed using 18 h cells grown in synthetic medium as a standard. Errors may be involved in producing the standard curve but since all experimental determinations of biomass are comparative to the standard cell, effective comparison between them is possible. Determination of biomass is preferable to the

determination of cell population. Changes in shape and size of organisms are not taken into account in cell population measurements. Changes in refractive index during growth in the presence of antibacterial agents will of course affect the calibration curve. The biomass was measured with a certainty of better than 0.01 mg cm^{-3} .

As the oxygen electrode was placed (of necessity) at some distance from the microcalorimeter cell, there was always a possibility that the oxygen tension recorded differed from that in the microcalorimeter cell. Since the electrode causes depletion of oxygen from the medium, it was essential that the rate of pumping across the electrode be as high as possible. Oxygen tension was measured with an accuracy of $\pm 3\%$ oxygen saturation.

The pH of the culture was measured by passing the culture over a glass electrode/reference electrode system. The accuracy was ± 0.05 pH.

The glucose concentration in the medium was determined using the α -toluidine method (Dubowski, 1962). This method was used in preference to a specific enzyme system because of its simplicity and speed. The use of glucose oxidase (Washko and Rice, 1961) in the form of the Worthington 'glucostat' kit necessitated the adjustment of each sample to a neutral pH. The extracellular glucose concentrations were measured with a precision of $\pm 0.003 \text{ mg cm}^{-3}$. A more significant experimental error involved in the determination of the glucose concentration at any particular time is the uncertainty in assessing the exact time of sampling.

By carefully controlling the culture conditions, for example by using a standard volume of medium of fixed composition

and a standard volume of inoculum of known age etc., it was possible to obtain consistently reproducible thermograms and changes in other environmental properties. Thus the total heat evolved can be measured with an accuracy better than $\pm 6-7\%$. This means that a variation in the heat evolved by more than 10% was significantly different. It must be borne in mind that the heat evolved refers to organisms contained in 1.2 cm^{-3} of culture contained in the microcalorimeter cell and not to the cells in the culture vessel.

When cells of K. aerogenes were grown in antibiotic-free medium, a characteristic thermogram and characteristic patterns of variation of environmental properties were obtained (Figure 3.1). In this type of microcalorimetry it is essential that such information as pH, oxygen tension of the medium etc. be recorded, to permit the interpretation of the thermogram in terms of changes in biological properties. Since bacterial populations of less than about 10^5 organisms cm^{-3} do not produce measureable heat outputs, a large inoculum was always used. This reduced the duration of each experiment and prevented the growth vessel running dry as a result of prolonged sampling; this also helped to reduce accumulation of bacterial debris on the walls of the microcalorimeter cell. The large inoculum resulted in a high biomass being rapidly obtained after a negligible lag phase. This use of such a large inoculum and the consequent short lag phase, prevented studies on heat output during the lag phase for growth in drug-free medium.

As bacterial growth proceeded, the glucose concentration in the medium fell and the oxygen tension dropped rapidly, indicating that the oxidative processes of the Krebs cycle were in operation.

The level of oxygen had a marked effect on the heat output. Thus when the oxygen tension fell to 15% at a biomass of about 0.13 mg cm^{-3} , there was a marked decrease in heat output (regardless of the initial glucose concentration). Subsequent increase of biomass resulted in oxygen starvation and this in turn caused a marked increase in the relative amount of fermentation taking place; K. aerogenes is a facultative anaerobe. This increase in the amount of fermentation products caused the pH of the growth medium to fall rapidly as acid was produced by the growing bacteria. The minimum pH value of the culture depended on the initial glucose concentration in the medium. With an initial glucose concentration of 0.5 g dm^{-3} the minimum pH was 6.7. With an initial glucose concentration of 2.0 g dm^{-3} the minimum pH was 5.5.

Winzler (1941) and Hixson and Gedden (1950) among others have attempted to establish the value of oxygen tension at which the rate of respiration decreases for various organisms. Harrison and Pirt (1961) found that for K. aerogenes, for glucose-limited growth in simple salts medium at pH 6, the critical value of oxygen tension was 7-10% saturation.

The specific thermogram expressing heat evolved per unit biomass per minute ($\text{J mg}^{-1} \text{ min}^{-1}$) showed that most heat is evolved during the exponential phase of growth. The specific thermogram passed through a maximum value about half way through the exponential phase and then decreased rapidly. This decrease corresponded to the onset of increasing fermentation as the oxygen tension fell. Other reports have indicated that during exponential growth the specific heat output remains constant at the highest level reached by the

bacterial cells (Forrest et al, 1961; Forrest and Walker, 1964). However, growth limitation by any cause reduces the catabolic activity of bacterial cells (Forrest, 1969) and the decrease in oxygen tension in the current study may be the cause of the decrease of the specific heat output.

A sudden decrease in the heat output occurred at the point when the maximum growth was attained. Both the fall in heat output and the onset of the stationary phase were apparently due to the exhaustion of the glucose supply in the medium (and possibly oxygen limitation) at this point. The stationary phase however, did not mark a large fall in heat production as considerable metabolic activity continued for some hours at a slowly decreasing rate until a sudden, final decrease in heat output occurred. This high metabolic activity during the stationary phase appears to be due to the oxidation of secondary energy sources, namely, the acids produced by the bacteria during the exponential growth phase. Evidence for this was given by the rise in the pH of the medium, and by the continued oxygen depletion until the acid substrates were used up (when the pH almost returned to its original value). At this point, the heat output fell and the oxygen tension rose almost to its original value.

The exact nature of the acid products of the growth phase are not known. Harrison and Pirt (1967) have reported that under glucose-limited conditions, cells of K. aerogenes grown in simple salts medium at pH 6, produce 2,3-butanediol, acetic acid and ethanol, whilst Eriksson and Wadsö (1971) have related heat production in the stationary phase of cells of E. coli grown in simple glucose medium, with the presence of acetate. In the current study, analysis of the

growth medium showed that acetic acid was present. Furthermore, experiments in which acids (acetic, pyruvic and lactic) were added to cultures, which had reached the late stationary phase, showed that these acids were metabolised oxidatively. The observed pH, oxygen tension and heat output changes were consistent with those occurring with normally growing cultures during their stationary phase.

The small, sharp rise in the oxygen tension which occurred at the onset of the stationary phase may be due to the anaerobic conversion of the acids back to pyruvate, which is subsequently used in respiration as it becomes available. This availability and use thus caused the oxygen tension to fall again.

After the final fall in heat output, the heat output did not fall to its original baseline, unless formalin was added to kill the bacteria. The small but measureable evolution of heat indicated that endogenous metabolism was still in progress.

When a known amount of acetic acid was added to the culture in the late stationary phase, there was evidence of further metabolism by the bacteria using acetate as a substrate (Figure 3.3). The calculated heat evolved for the oxidation of 1 mole of acetic acid by the bacteria under these conditions was 550 kJ (Table 3.3), as compared to a value of 1004 kJ for the complete oxidation of 1 mole of acetic acid. Such a result suggests that the bacteria at this stage are only about 50% energetically efficient.

The duration of time between the onset of the stationary phase and the second, sharp fall in the heat output, and hence the

heat evolved during this phase of the growth cycle is dependent on the amount of acidic products of fermentation accumulated in the medium. If it is assumed that there is no oxidative breakdown of acids prior to the onset of the stationary phase and that there are no further anabolic processes resulting in the formation of cellular material during the stationary phase, it is possible to calculate the number of moles of acid produced from the breakdown of the original glucose. Such a calculation shows that about 8 mmol of acetic acid were oxidised to give the heat evolved during this phase of the growth cycle, from an initial glucose concentration of $11.1 \text{ mmol dm}^{-3}$.

For the purposes of discussion it is convenient to divide the thermograms obtained during the growth of cells of *K. aerogenes* into sections (Figure 7.1).

Figure 7.1

Diagrammatic representation of a measured thermogram

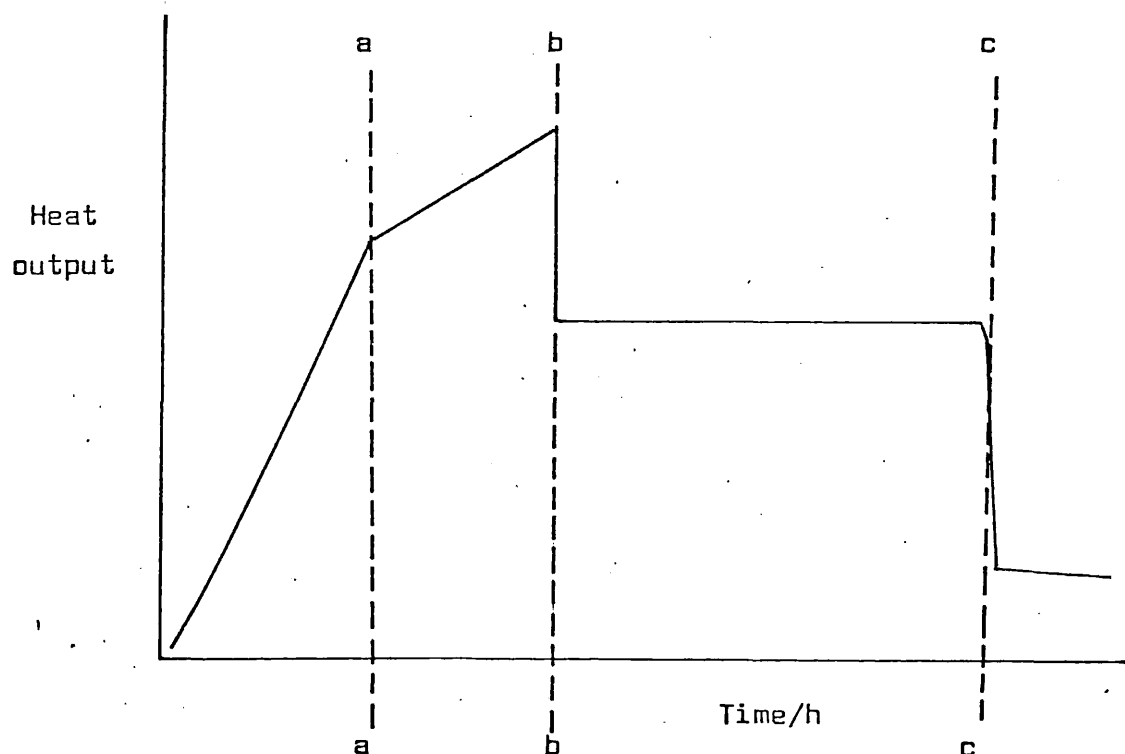

- (i) The region between inoculation and aa, is the time of rapid exponential growth, with the catabolic degradation of glucose providing energy for the anabolic processes of cell synthesis. The evolution of excess heat, as detected from specific thermograms, indicates that the organisms are becoming increasingly more thermally inefficient. At aa the rate of increase of heat output declines as oxygen tension falls to $\sim 15\%$.
- (ii) Between aa and bb the the rate of increase of heat output continues at a new, lower rate. As a result of the depleted oxygen tension, not all the pyruvate can be utilised via the Krebs cycle and thus acidic fermentation products e.g. acetic acid, are increasingly produced. At the end of this phase, oxygen tension in the culture is fully depleted and the glucose concentration exhausted. Also the pH has reached a minimum value due to the accumulation of acidic products.
- (iii) Between bb and cc there is a constant, reduced heat output due to the oxidative metabolism occurring. The oxygen tension in the medium is very low ($\sim 2-3\%$), as would be expected for the operation of the Krebs cycle and electron transport processes. During this period the pH of the culture increases steadily; the oxygen tension increases sharply only when the secondary metabolism of acidic products is complete.

By having these fixed regions where known metabolic processes occur, it is possible to make a more detailed quantitative comparison of heat changes under different growth conditions.

The results obtained were essentially similar for growth of cells of K. aerogenes in different concentrations of glucose. The initial, rapid fall in oxygen tension was independent of glucose concentration and attained a value of about 15% at the first break, aa, in the thermogram. This corresponded to a biomass of about 0.13 mg cm^{-3} . The similarity of these results is explicable in terms of glucose at aa not being exhausted for any initial concentration. The heat evolution from aa to bb, and from bb to cc, increased with increasing glucose concentration. In addition, the biomass at bb was dependent on glucose concentration and the minimum pH value decreased with increasing initial glucose concentration in the growth medium. After aa there is thus a correlation between the availability of glucose and the extent of metabolic activity and growth of the bacterial cells.

When cells of K. aerogenes were grown in the presence of penicillin, the cells grew normally at first to a biomass of about 0.03 mg cm^{-3} . The culture then suddenly ceased to grow, the heat output and oxygen tension almost returned to their original baseline values, and the absorbance fell due to cell lysis. The time from inoculation to the cessation of growth decreased with increasing penicillin concentration. These results (Table 4.2) are in line with the known mode of action of the penicillin drugs. The antibiotic acting on the growing bacterial cells inhibits peptidoglycan synthesis by preventing the formation of the penta-glycyl peptide cross-linkages. Daughter cells produced by cell division thus have weakened cell walls, making them osmotically fragile and resulting in their

lysis, thus accounting for the decrease in absorbance of cultures growing in the presence of penicillin. A lag phase then followed, during the latter part of which there was a slight heat output indicative of some slight metabolic activity. The length of the lag phase depended upon the concentration of penicillin, the higher the concentration the longer the lag phase. After this, bacterial growth began again and this time the normal pattern of growth as detected by thermogram, pH changes etc. was obtained (except that the growth rate was reduced compared with drug-free growth).

The findings were similar when cells of K. aerogenes were grown in the presence of different concentrations of methicillin and carbenicillin. This is consistent with these antibiotics having similar mechanisms of action to penicillin G. A comparison was made between the actions of these antibiotics by standardising the conditions of growth, using a set inoculum in a known volume of medium containing a fixed comparable concentration of antibiotic, $\frac{1}{2}$ x MIC (Figure 4.2). In this way, the time course of the effects of the antibiotics on the bacteria was examined. Carbenicillin had the most marked bacteriostatic effect on the bacterial cells, causing the cessation of initial growth more rapidly than methicillin, and delaying final growth for a longer period than either of the other two antibiotics. Methicillin was the least effective in this respect. Mårdh et al (1976) have reported similar differences in the kinetics of the actions of various tetracyclines using this technique. Such microcalorimetric studies may be of use in determining optimum doses and dose intervals in clinical therapy, in order to help to maximise the bacteriostatic effect of various antibiotics.

The total heat evolved during the growth of cells in the presence of these antibiotics tended to be less than the total heat evolved when the cells were grown in drug-free medium. The greatest reduction was observed during the stationary phase, bb to cc, during which time secondary metabolic processes are occurring. The increase in pH during this phase provided evidence that such processes occurred in the presence of the penicillin-type antibiotics. The heat evolved during the actual growth cycle (i.e. neglecting that during the initial growth and lysis) in the presence of methicillin (Table 4.2) was approximately 50% of that evolved during growth in drug-free medium. Since the heat evolved is a measure of the inefficiency of the organisms, it would seem that the organisms require considerable amounts of energy to overcome the inhibition by methicillin, more so than for either of the other two penicillins.

The biomass was unaffected by growth in the presence of penicillin and carbenicillin, but in the presence of methicillin the final biomass at bb was slightly less (15%) than that in drug-free medium. This may be related to the high biomass achieved in the presence of methicillin during the initial growth phase; this growth decreased the glucose concentration and thus in turn, resulted in a reduced final biomass. The higher value for the minimum pH at the onset of the stationary phase supports this conclusion.

In the experiments with the penicillin antibiotics (and other antibacterial agents used), the bacteria grew at antibiotic concentrations equal to or higher than the MIC values. This may be because the large inoculum used in these studies effectively reduced the antibiotic concentration as less antibiotic molecules are

available per bacterial cell than at lower initial bacterial concentrations. The subsequent MIC of penicillin of cells grown once in the presence of penicillin G was $200 \mu\text{g cm}^{-3}$, suggesting that the selection of resistant mutants or the acquisition of in vitro resistance was not the reason for the growth at high concentrations.

Familiarisation of strains to particular concentrations did occur however. Thus when cells of K. aerogenes grown once in $100 \mu\text{g cm}^{-3}$ carbenicillin were subsequently grown at this same concentration, there was no lag phase or lysis. These bacteria also grew at high concentrations of methicillin and penicillin and at $300 \mu\text{g cm}^{-3}$ of carbenicillin, with slight or no pause in growth. The mechanism by which such training to antibiotic molecules occurs, enabling bacteria to be completely or partially unaffected when grown in the presence of the antibiotics, is not known. In this case mutational changes may be occurring, or it may be that alternative metabolic pathways are being used more fully and more effectively. Even though the MIC of antibiotic may not be altered in the first instance, continued subculturing at a significant concentration of antibiotic will in time lead to an increase in the MIC value. This process provides the basis for in vitro training to antibiotics.

Cells which had been repeatedly grown at $400 \mu\text{g cm}^{-3}$ penicillin G, when grown at this concentration, exhibited a thermogram and changes in other physical properties, which were very similar to those for control cells growing in antibiotic-free medium (Table 4.2). The total heat evolved was the same as for control cells. This suggests that whatever changes to the metabolic pathways occurred during the first subculture in the antibiotic, the

acquisition of in vitro resistance has altered these, so that the trained cells appear to be very similar to the normal, untrained cells growing in drug-free medium, from the energetic point of view.

The mode of action of gentamicin is to inhibit protein synthesis, the ribosomes being the site of action. When cells of K. aerogenes were grown in the presence of concentrations of $\frac{1}{2}$ and 2 x MIC of gentamicin, the time required to reach maximum growth was increased. At low concentrations of gentamicin the total heat evolved and the biomass at bb was the same as for growth in drug-free medium. However, the metabolic balance of the cells was altered by the presence of the drugs, as the heat evolved during different phases of the growth cycle (from inoculation to aa, from aa to bb, and from bb to cc) were considerably different compared with drug-free growth (Table 4.4). At a higher concentration (4 x MIC) of gentamicin, a prolonged lag phase was produced after a brief period of initial growth. Also, there was a most dramatic difference in the heat output as compared to normal. During this lag phase there was a considerable heat output and this continued into the exponential growth phase. The increased heat output during the lag phase is most clearly seen from the specific thermogram, which in fact shows a maximum specific heat output in the lag phase. The shapes of the measured thermograms were different to those obtained during growth in drug-free medium or in the presence of lower concentrations of gentamicin; this resulted in a 100% increase in the total heat evolved during the growth cycle (Table 4.4). The heat output fell rapidly at aa, instead of the rate of increase becoming reduced at this point as in drug-free growth. As a result, aa marked the position of maximum heat output, instead

of bb as with normal drug-free growth. Thus even when the cells overcame the effects of the antibiotic and grew, the presence of the drug had a marked effect on their metabolism. At the onset of the stationary phase, where the pH was minimal and oxygen tension depleted, the heat output attained a constant lower value. This was maintained for some 5 h, during which time, acids which had accumulated during growth, were oxidatively metabolised. At the end of this time the heat output decreased again and the oxygen tension increased to about 80%.

After 50 consecutive subcultures in the presence of $0.2 \mu\text{g cm}^{-3}$ ($4 \times \text{MIC}$) of gentamicin, the mgt was decreased considerably and there was no lag phase. These trained cells now grew to the same biomass but with a drastically reduced heat output compared with untrained cells growing at this concentration; the total heat evolved during growth was the same as that of control cells. This suggests a much greater ease of growth at this concentration as a result of training.

Carter and Dean (1975) have discussed gentamicin-resistance in K. aerogenes and in particular the way in which resistance is graded to the concentration at which the training was performed. Furthermore, they have pointed out that this phenomenon is interpretable in terms of progressive changes in the enzyme balance of the organisms.

Nalidixic acid inhibits DNA synthesis in bacteria. Low concentrations of nalidixic acid had little effect on the thermogram or other properties recorded during the growth of cells of K. aerogenes in the presence of the antibiotic. However, growth at

higher concentrations (5 and 7 x MIC) resulted in a phase of initial growth, followed by a cessation of growth and a fall in heat output. The results agree with the report of Dean and Moss (1970), that the action of nalidixic acid is dependent on growth rate. Once again this appears to be a case of a bacteriocidal antibiotic acting bacteriostatically, the length of the lag phase increasing with concentration. At the end of the lag phase the cells began to overcome the effects of nalidixic acid and exponential growth followed. However, the growth rate of the cells was still impaired by the presence of the antibiotic, even though the final biomass was the same as for growth in the absence of the drug. Thus the mgt was progressively increased with increasing concentration of nalidixic acid (Table 4.5) and the total heat output was also reduced compared to drug-free growth. This again suggests the utilization of energy to overcome the inhibitory effects of the drug. The thermogram (Figure 4.5) differed from that obtained during drug-free growth in having a second peak at the beginning of the stationary phase and in having no plateau value between bb and cc. The variation of the pH and oxygen tension of the culture medium with time is evidence of the presence of oxidative processes involving the breakdown of acidic material; there was a considerable heat output in this region but it was not constant. The effects of the antibiotic were also seen in the variation of heat output in the different regions of the thermogram. These differed markedly from growth in drug-free medium, being higher between the end of the lag phase and aa, but lower between aa and bb, and between bb and cc. The cells did not acquire any enhanced resistance to nalidixic acid as a result of one subculture in its presence.

Although there was a negligible lag phase when cells of K. aerogenes were grown in sulphanimide ($\frac{1}{2}$, 2 and 3 x MIC), the time required to reach the stationary phase was extended with increasing concentration. Diphasic growth (Carter and Dean, 1976), in which the rate of increase of biomass decreased after an initial period of growth, was observed. The μ_{gt} values appropriate to the two phases of growth, increased with each increase of drug concentration, i.e. the rate of growth decreased.

Sulphanilamide acts as a competitive inhibitor of folate synthesis and the recorded heat output reflected altered growth characteristics of cells in the presence of high concentrations of the drug. Thus the shape of the thermogram was markedly different, a second maximum heat output occurring in the stationary phase (after bb), instead of the normal constant heat output of control cells in this region. The heat evolved in the different regions differed from those during drug-free growth (Table 4.6); the heat evolved between inoculation and aa, and between aa and bb was higher, and the heat evolved between bb and cc was lower at concentrations of 200 and 800 $\mu\text{g cm}^{-3}$. The total heat evolved was unchanged by growth at these concentrations of the drug. Growth at 1200 $\mu\text{g cm}^{-3}$ of sulphanimide however, gave a much increased total evolution of heat, i.e. the cells were even more energetically inefficient. Again all the evidence pointed to the presence of secondary metabolic processes after the onset of the stationary phase; processes which require large amounts of energy and which are associated with the removal of acidic material.

The effects of the drug were much less marked with cells which had been trained to grow at a concentration of 1200 $\mu\text{g cm}^{-3}$

of sulphanilamide. When subsequently grown at this concentration of sulphanilamide the trained cells showed no biphasic growth, grew more rapidly than untrained cells at this drug concentration and exhibited a normal drug-free type of thermogram with no second peak. The heat evolved during the various phases of growth and the total heat evolved were comparable to these values for the growth of untrained cells in drug-free medium.

The growth of cells of K. aerogenes at a concentration of $\frac{1}{2}$ x MIC of proflavine resulted in a delay in heat output due to the long lag period. Once growth resumed (9 h after inoculation), the general pattern of heat output, albeit at a reduced rate, was very similar to that for growth in drug-free medium, until the onset of the stationary phase at bb. However, the final biomass attained at bb was reduced compared with drug-free growth. Although metabolic processes were still evident, the phase of secondary metabolism where acetic acid is metabolised, was absent. This was confirmed by the increase in oxygen tension at bb, and the continuing low pH value. The total heat evolved from inoculation to bb was considerably greater than that for drug-free growth over the same regions. The process of growth was thus considerably impaired compared with the growth of cells in drug-free medium.

These effects were minimised when trained cells ($25 \mu\text{g cm}^{-3}$) were subsequently grown at this concentration of the drug. Thus after a brief lag phase the cells grew at a faster rate than untrained cells growing at this concentration. The thermogram was of the drug-free type with evidence that secondary oxidative metabolic processes were occurring; the total heat evolved was

the same as that for growth in the absence of the drug.

Thus studies of energy changes during growth in the presence of various antibiotics and drugs have revealed changes in metabolic pathways for cells of K. aerogenes. In some instances there was a conservation of energy to overcome the presence of the drug. It is difficult to conceive of a mechanism, whereby the organisms are more energetically efficient when growing in the presence of the drug; further investigations are necessary. Despite the differing modes of attack of the antibacterials studied, there are certain similarities in the experimental results. Thus when very low concentrations of drugs were used there was no difference between the thermogram and that of the control. Higher concentrations of drug produced different shaped thermograms, but in general the three regions of the control thermogram could be recognised. With the exception of proflavine, there was evidence of the occurrence of secondary metabolic processes to remove acidic products oxidatively. Cells trained to grow in the presence of the antibacterial agents, when subsequently growing in the presence of these agents, exhibited thermograms which were similar in shape and position to those of control cells. Furthermore, the total heat evolved was the same as that of control cells.

Serum levels of gentamicin greater than $12 \mu\text{g cm}^{-3}$ are seriously ototoxic (Jao and Jackson, 1963; Wörsall et al, 1969)

and so are avoided in clinical medicine. This fact was utilised in this study as a method of defining gentamicin-resistance and sensitivity; a gentamicin-resistant strain of P. aeruginosa is one with an MIC of gentamicin greater than $12 \mu\text{g cm}^{-3}$ and a sensitive strain is one with an MIC less than, or equal to, $12 \mu\text{g cm}^{-3}$.

Four different strains of P. aeruginosa were examined to compare their growth in synthetic medium in the presence and absence of gentamicin. One gentamicin-sensitive strain (strain 1), two highly gentamicin-resistant strains (in which the resistance was not due to the presence of R-factors mediating gentamicin-resistance) and strain Capetown no. 18 (possessing R-factor mediated gentamicin-resistance) were used.

The same growth medium and other growth conditions, such as size of inoculum etc., as for cells of K. aerogenes, were used. All the strains had a short lag phase when inoculated into the synthetic medium. During the phase of experimental growth the heat output increased for all strains (Figures 5.1 to 5.4). A decrease in the rate of increase of heat output was evident for the two resistant strains (such as was seen with cells of K. aerogenes), but not with the sensitive strain or the R-factor strain. The heat output attained a maximum value for all four strains and then fell rapidly. For cells of strain Capetown no. 18 this decrease, which occurred at the end of the exponential growth phase, was accompanied by a marked increase in oxygen tension. For the other three strains, the heat output fell to a constant value (higher for the sensitive strain), which was then maintained for some hours until there was an increase in oxygen tension, when the heat

output fell to a small value.

The glucose supply in the growth medium was only exhausted when the oxygen tension in the medium started to increase. The oxygen tension fell rapidly at the start of growth, and as it became depleted, the pH of the growth medium began to fall more rapidly, indicating that fermentation was occurring increasingly. However, in contrast to cells of K. aerogenes, when the glucose was exhausted, not only did growth cease, but the oxygen tension rose rapidly. The pH of the medium did not increase, indicating that P. aeruginosa does not or cannot use the acid fermentation products as a secondary energy source.

When acetic acid was added to cells in the stationary phase (Figure 5.2), there was an initial fall in pH, followed by a period during which a heat output was recorded and there was a gradual rise in pH. The absence of such evidence of secondary metabolism in normally growing cultures, suggests that these four strains of P. aeruginosa do not produce acetic acid or other easily metabolised acidic material, as fermentation products.

Growth of cells of all four strains in this particular medium was slower than that of cells of K. aerogenes. This may be due to the low concentration of calcium and magnesium ions in the medium, which are important in P. aeruginosa for the maintenance of cell envelope integrity. A tendency to clumping by the bacterial cells of the P. aeruginosa strains used, made accurate monitoring of the absorbance difficult. For this reason, growth curves, specific thermograms and mgt values were not assessed, although an indication of the onset of the stationary

phase was obtained from absorbance readings of samples removed from the culture.

When gentamicin was included in the growth medium at a concentration of 4 x MIC of each strain, the lag phase and the time required to reach the stationary phase was increased. The magnitude of this increase varied between strains.

The shapes of the thermograms were similar for growth in the presence and absence of gentamicin for cells of strains 1, 100 and Capetown no. 18 (Figures 5.5, 5.7 and 5.8). However, the pattern of heat output for cells of strain 100 was altered by the presence of the antibiotic (cf. Figures 5.2 and 5.6). After reaching the maximum value, the heat output now fell rapidly at the onset of the stationary phase, without exhibiting a plateau value. The thermogram was thus similar in shape to that of the R-factor carrying strain Capetown no. 18 (cf. Figures 5.6 and 5.8).

The total heat evolved during the growth of cells of strains 1, 100 and 104 was largely unchanged by growth in the presence of gentamicin compared with drug-free growth. The heat evolved by cells of strain Capetown no. 18 was significantly higher than that of cells of the same strain grown in drug-free medium. This increased heat production may be due to the operation of gentamicin-inactivating enzymes by these cells, and their subsequent interaction with, and inactivation of gentamicin molecules.

This preliminary study of cells of P. aeruginosa with differing levels of resistance to gentamicin, has revealed differences in metabolic processes which are worthy of more

detailed study. In any extension of this work it will be necessary to use a synthetic medium with proper control of calcium and magnesium ion concentration, in which there is improved growth. Also it is necessary to establish a means of monitoring biomass.

Bryan and Van Den Elzen (1975) have reported that gentamicin uptake by bacterial cells consists of a first stage firm binding to the bacterial surface, followed by an energy requiring process which results in the antibiotic being taken into the cells. A batch-cell microcalorimeter was used in an attempt to detect the initial binding of the drug to cells of K. aerogenes and P. aeruginosa. The results (Table 5.2) indicate a small exothermic reaction in each case. The heat output for the interaction with cells of the highly resistant strain 100 is significantly smaller than that for the other three strains. This could mean that there are a smaller number of binding sites for gentamicin on cells of this strain, which could be directly related to resistance to gentamicin. If this is the case, cells of Capetown no. 18 which is also resistant to gentamicin, could easily give similar results to the gentamicin-sensitive strains, since possessing gentamicin-inactivating enzymes, they would perhaps have less need for a 'barrier' type resistance mechanism. This antibiotic/cell interaction is also worthy of more detailed investigation.

Five strains of P. aeruginosa were examined in an attempt to relate possible differences in qualitative or quantitative

content of macromolecular components with differing levels of resistance to gentamicin. Strain 1 was gentamicin-sensitive; strain 1A/20 was 'trained' by repeated subculture in the presence of increasing concentrations of the antibiotic to be moderately resistant; strain 107 had 'natural' moderate resistance and strains 100 and 104 were highly resistant.

The results of the lipid analysis were in agreement with previous reports (Sinha and Gaby, 1964; Gordon and MacLeod, 1966) that phosphatidyl ethanolamine is the predominant phospholipid component of cells of P. aeruginosa. Vaczi et al (1964) and Bobo and Eagon (1968) reported that diphosphatidyl glycerol (cardiolipin) is a phospholipid component in cells of P. aeruginosa and this was also confirmed in the present study. No lecithin-type phospholipid was detected in the lipid extracted from the five strains. In fact, the presence of this phospholipid component has been the subject of some doubt. Vaczi et al (1964) and Sinha and Gaby (1964) reported its existence in P. aeruginosa, while Goldfine and Ellis (1964) and Bobo and Eagon (1968) failed to discover any phosphatidyl choline in a large number of bacterial species, including P. aeruginosa.

A comparison of results of lipid analysis for the five strains, showed that there was no significant difference between the total lipid content of each strain, nor were there any differences in the lipid components detected qualitatively. However, strain 100, the most highly gentamicin-resistant strain, possessed significantly more neutral lipid and less phospholipid than the other four strains (which all had essentially the same neutral lipid/phospholipid ratio).

In a parallel electrophoretic study of P. aeruginosa cells Chapman (1976) determined pH-mobility curves and S-values for strains 1, 100, 104 and 107. Strain 1 had a pH-mobility curve characteristic of gentamicin-sensitive cells of P. aeruginosa, whilst cells of strains 100, 104 and 107 had a different type of pH-mobility curve, characteristic of gentamicin-resistant cells. S-values, a measure of surface lipid (Marshall and James, 1971), were obtained from the increase in negative mobility of cells measured in the presence of sodium dodecyl sulphate (SDS), compared with cells of the same strain measured in the absence of SDS. SDS is a surface active anionic agent, the hydrophobic hydrocarbon chain of which molecule interacts reversibly with the surface lipid, leaving the polar hydrophilic sulphate groups protruding into the medium (Dyar, 1948). This results in an increase in anionic mobility of the cells in proportion to the amount of lipid at the surface.

Cells of strain 1 had negligible surface lipid, whilst the cells of the other three strains had significant amounts of surface lipid (Table 6.2). These results indicate that some redistribution of lipid in the cell wall may have occurred in strains 104 and 107 to give rise to the higher S-values, since these strains have the same total lipid as does strain 1. The high S-value of strain 100 may also have been caused by some such mechanism or as a result of the higher neutral lipid to phospholipid ratio of this strain.

In an earlier study, strain 1A/20 was analysed both for bulk and surface lipid components (Pechey et al, 1974). The lipid

composition and the pH-mobility curve of cells of strain 1A/20 were the same as for cells of the parent strain 1. This indicated that cells of the two strains had the same charge density on the surface. However, only for cells of the trained strain was any significant amount of surface lipid detected. It is apparent that the presence of this lipid had caused no change in the charge density on the surface. It can thus be inferred that the surface lipid on cells of strain 1A/20 was neutral lipid, which had been transferred to the surface by some re-orientation of the cell wall components.

In the previous study, cells of strains 1 and 100 were also examined, as well as strain B.32 which had the same level of resistance ($25 \mu\text{g cm}^{-3}$) as strain 107. The lipid analyses were the same as in the current study, for cells of strains 1 and 100; strain B.32 was similar to strains 1, 104 and 107. However, over a period of some three years the MIC of gentamicin of strain B.32 has fallen so that it is now classified as gentamicin-sensitive. There have been corresponding changes in the shape of the pH-mobility curve and the S-value, which are now characteristic of sensitive cells. No such change has occurred with the MIC value or pH-mobility curve for the highly resistant strain 100, suggesting a difference between the type of resistance of this and the other strains. There has been a fall in the S-value of cells of strain 100 over the intervening years, but the identical lipid analysis results at the different times indicate a redistribution of lipid rather than a decrease in total cell lipid.

These results tend to indicate a relationship between resistance and surface lipid, particularly for strain 100, where

the electrophoretically detected differences are matched by differences in the proportions of neutral and phospholipid, compared with the sensitive strain 1.

Other workers have reported a correlation between the lipid content of bacterial cells and their resistance to antibiotics and antibacterial agents. Hugo and Stretton (1966) showed that the induced appearance of lipid on the surface of cells of Staphylococcus aureus was accompanied by an increase in the resistance of the cells to antibiotics of the penicillin type. Similarly, cells and cell envelopes of P. aeruginosa resistant to polymixin possess less phospholipid than do the cells of polymixin-sensitive strains (Brown and Wood, 1972). From this it was postulated that phospholipid may be specifically required to aid the passage of the antibiotic into the cell. Such a situation may also occur in cells of strain 100, which contained less phospholipid than the cells of less gentamicin-resistant strains. The higher levels of electrophoretically detected surface lipid on cells of the resistant strains compared with cells of the sensitive strain 1, also fit in with such an exclusion mechanism of resistance. However, the decrease in surface lipid over a three year period for strain 100, without any corresponding loss of gentamicin-resistance, would seem to be contrary to the idea of such a barrier mechanism. Possibly the lipid is now lying in a less external position and is thus not detected electrophoretically, but is still acting as part of a resistance mechanism.

The analysis of DNA and RNA content showed that the cells of the five strains had equal amounts of these components. The

analysis of polysaccharide and protein contents revealed a pattern similar to that of the lipid content, in which cells of strain 100 gave different results from the other four strains. This strain had more polysaccharide and less protein than the other strains (Table 6.4). The amino acid analysis (Table 6.3) confirmed the protein results; each of the eighteen amino acids detected was present in equal amounts (within experimental errors) in cells of strains 1, 1A/20, 104 and 107 but was present in smaller amounts in strain 100. The most abundant amino acid in cells of strain 100 was glycine, whilst alanine was the most abundant in the other strains. It is thus apparent that the composition of the protein is the same for cells of strains 1, 1A/20, 104 and 107, but different from that of the highly resistant strain 100. Separate research in this laboratory (Chapman, 1976) has shown that when cells of a gentamicin-sensitive strain of P. aeruginosa (strain B.32) are grown in calcium-deficient and calcium-sufficient media, the MIC of gentamicin of the cells grown in the latter medium is higher than that of cells grown in the former medium. Also the cells grown in the calcium-sufficient medium have a higher polysaccharide and a lower protein content, similar to the result for the resistant strain 100.

In conclusion, analytical results showed that the most highly resistant strain, strain 100, had marked differences in lipid, protein and polysaccharide content from the other resistant and sensitive strains. This may be due to the fact that strain 100 has a different resistance mechanism to the other resistant strains. In fact, working from the available information, the mechanisms

of resistance in these strains can only be a matter of speculation. Work in this laboratory has consistently failed to demonstrate the presence of transmissible R-factor mediated resistance in these strains (Chapman, 1976). Electrophoretic studies on cells of P. aeruginosa indicate a relationship between resistance to gentamicin and cell surface changes involving increased surface lipid, suggesting some form of barrier mechanism of resistance. In this case, the increased polysaccharide content of cells of strain 100, compared with that of less resistant strains, could point to increased amounts of cell surface lipopolysaccharide. However, it is quite possible that the differences between different strains are a result of the mechanism (or mechanisms) of resistance and not a direct cause of resistance.

This report has shown the usefulness and the application of flow-cell microcalorimetry in following the sequences of events during the growth of cells of K. aerogenes and P. aeruginosa in the presence and absence of antibacterials. Changes in the total heat evolved during growth, and occasionally changes in the nature of the thermogram, due to the presence of antibiotics, have been detected, and where possible related to biological processes occurring during the growth cycle. A knowledge of changes in other properties of the cells and culture medium is essential to any detailed interpretation of the thermogram.

Chemical analysis of cells of strains of P. aeruginosa revealed that cells of a very highly resistant strain had a

different lipid, protein, amino acid and polysaccharide content to other resistant and sensitive strains.

BIBLIOGRAPHY

- Barber, M. and Waterworth, P.M., (1966), *Brit. Med. J.*, 1, 203
- Batchelor, F.R., Doyle, F.P., Nayler, J.H.C. and Rolinson, G.N., (1959), *Nature*, 183, 257
- Battley, E.H., (1960), *Physiol. Plantarum*, 13, 192
- Bayer, M.E. and Remsen, C.C., (1970), *J. Bact.*, 101, 304
- Belaich, J.-P., (1963), *Compt. Rend. Soc. Biol.*, 157, 316
- Binford, J.S., Binford, L.F. and Adler, P., (1973), *Am. J. Clin. Pathol.*, 59, 86
- Bobo, R.A. and Eagon, R.G., (1968), *Can. J. Microbiol.*, 14, 503
- Boivinet, P., (1964), Ph. D. Thesis, Univ. of Marseilles
- Boling, E.A., Blanchard, G.G. and Russel, W.J., (1973), *Nature, Lond.*, 241, 472
- Bouffard, A., (1895), *C. r. hebd. Séanc. Acad. Sci. Paris*, 121, 357
- Braun, V. and Bosch, V., (1972), *Proc. Nat. Acad. Sci. U.S.A.*, 69, 970
- Braun, V. and Rehn, K., (1969), *Eur. J. Biochem.*, 10, 426
- Braun, V., Rehn, K. and Wolff, H., (1970), *Biochem.*, 9, 5041
- Braun, V. and Sieglin, U., (1970), *Eur. J. Biochem.*, 13, 336
- Braun, V. and Wolff, H., (1970), *Eur. J. Biochem.*, 14, 387
- Brown, J.L. and Johnson, J.M., (1962), *J. Lipid Research*, 3, 480
- Brown, M.R.W. and Melling, J., (1969a), *J. gen. Microbiol.*, 54, 439
- Brown, M.R.W. and Melling, J., (1969b), *J. gen. Microbiol.*, 59, 263
- Brown, M.R.W. and Wood, S.M., (1972), *J. Pharm. Pharmacol.*, 24, 215
- Bryan, L.E., Shahrabadi, M.S. and Van Den Elzen, H.M., (1974), *Antimicrobial Agents and Chemotherapy*, 6, 191
- Bryan, L.E. and Van Den Elzen, H.M., (1975), *J. of Antibiotics*, 28, 696
- Brzezinska, M., Benveniste, R., Davies, J., Daniels, P.J.L., and Weinstein, J., (1972), *Biochem.*, 11, 761

- Burton, K., (1956), *Biochem.*, 62, 315
- Carson, K.J., and Eagon, R.G., (1966), *Can. J. Microbiol.*, 12, 105
- Carter, I.S. and Dean, A.C.R., (1975), *Microbios*, 14, 35
- Carter, I.S. and Dean, A.C.R., (1976), *Microbios Letters*, 1, 39
- Chapman, D.B., (1976), Ph.D. Thesis, London
- Chapman, D.B. and James, A.M., (1977), *Microbios*, In press
- Cheng, K.J., Ingram, J.M. and Costerton, J.W., (1970), *J. Bact.*, 104, 748
- Cheng, K.J., Ingram, J.M. and Costerton, J.W., (1971), *J. Bact.*, 107, 325
- Costerton, J.W., Ingram, J.M. and Cheng, K.J., (1974), *Bact. Reviews*, 38, 87
- Cox, S.T., Jr. and Eagon, R.G., (1968), *Can. J. Microbiol.*, 14, 913
- Crumplin, G.C. and Smith, J.T., (1976), *Nature*, 260, 643
- Davies, J. and Nomura, M., (1972), *Annu. Rev. Genetics*, 6, 203
- Dean, A.C.R. and Moss, D.A., (1970), *Chem. Biol. Interactions*, 2, 281
- Delin, S., Monk, P. and Wadsö, I., (1969), *Sci. Tools*, 16, 22
- DePamphilis, M.C. and Adler, J., (1971), *J. Bact.*, 105, 396
- DeVoe, I.W., Costerton, J.W. and MacLeod, R.A., (1971), *J. Bact.*, 106, 659
- Dittmer, J.C. and Lester, R.L., (1964), *J. Lipid Research*, 5, 126
- Dubowski, K.M., (1962), *Clin. Chem.*, 8, 218
- Dubrunfaut, M., (1856), *C. r. hebd. Séanc. Acad. Sci. Paris*, 42, 945
- Dvorak, H.F., Wetzel, B.K. and Heppel, L.A., (1970), *J. Bact.*, 104, 542
- Dyar, M.T., (1948), *J. Bact.*, 56, 821

- Eagon, R.G., Simmons, G.P. and Carson, K.J., (1965), *Can. J. Microbiol.*, 11, 1041
- Elvidge, J.A. and Sammers, P.G., (1966), "A course in modern techniques of organic chemistry" (Butterworth)
- Eriksson, R. and Wadsö, I., (1971), *Proc. 1st Europ. Biophysics Congr.*, IV, 319
- Few, A.V., and Schulman, J.H., (1953), *J. gen. Microbiol.*, 9, 454
- Few, G.A., Yau, A.O.P., Prichard, F.E. and James, A.M., (1976), *Microbios*, In press
- Forrest, W.W., (1969), "Biochemical microcalorimetry" (Academic Press), p.165
- Forrest, W.W. and Walker, D.J., (1964), *Nature*, 201, 49
- Forrest, W.W., Walker, D.J. and Hopgood, M.F., (1961), *J. Bact.*, 82, 685
- Forsberg, C.W., Costerton, J.W. and MacLeod, R.A., (1970a), *J. Bact.*, 104, 1338
- Forsberg, C.W., Costerton, J.W. and MacLeod, R.A., (1970b), *J. Bact.*, 104, 1354
- Gale, E.F., Cundliffe, E., Reynolds, P.E., Richmond, M.H. and Waring, M.J., (1972), "The molecular basis of antibiotic action" (John Wiley and Sons, London), p.304
- Ghuysen, J.M., (1968), *Bact. Rev.*, 32, 425
- Gilleland, H.E., Stinnett, J.D., Roth, I.L. and Eagon, R.G., (1973), *J. Bact.*, 113, 417
- Glauert, A.M. and Thornley, M.J., (1969), *Ann. Rev. Microbiol.*, 23, 159
- Goldfine, H. and Ellis, M.E., (1964), *J. Bact.*, 87, 8
- Gordon, R.C. and MacLeod, R.A., (1966), *Biochim. Biophys. Res. Commun.*, 24, 684
- Goss, W.A., Dietz, W.H. and Cook, T.M., (1965), *J. Bact.*, 89, 1068

- Gould, J.C., (1960), Brit. med. Bull., 16, 29
- Hamilton, W.A., (1970), FEBS Symposium, 20, 71
- Hancock, R., (1960), Biochim. biophys. Acta, 37, 42
- Harrison, D.E.F. and Pirt, S.J., (1967), J. gen. Microbiol., 46, 193
- Henning, V., Rehn, K. and Hoehn, B., (1973), Proc. Nat. Acad. Sci. U.S.A., 70, 2033
- Hixson, A.W. and Gaden, E.L., (1950), Ind. Engng. Chem., 42, 1792
- Hotchkiss, R.D. and Evans, A.H., (1960), Fed. Proc., 19, 12
- Hugo, W.B., (1971), Inhibition and destruction of the microbial cell (Academic Press, London), p.200
- Hugo, W.B. and Stretton, R.J., (1966), J. gen. Microbiol., 42, 133
- Ivanov, Von W., Markov, K.I., Golowinsky, E. and Charisanova, T., (1964), Z. Naturforschg., 19b, 604
- Jacoby, G.A., (1974), Antimicrobial Agents and Chemotherapy, 6, 239
- Jao, R.L. and Jackson, G.G., (1963), Antimicrobial Agents and Chemotherapy (American Soc. for Microbiology, Washington), p.148
- Keleman, M.V. and Rogers, H.J., (1971), Proc. Nat. Acad. Sci. U.S.A., 68, 992
- Leive, L., (1968), J. Biol. Chem., 243, 2372
- Lerman, L.S., (1961), J. Molec. Biol., 3, 18
- Lickfield, K.G., Achterrath, M., Hentrich, F., Kolehmainen-Seveus, L. and Persson, A., (1972), J. Ultrastruct. Res., 38, 27
- Lindberg, A.A. and Hellerquist, C.G. (1971), J. Bact., 105, 57
- Lindström, E.B., Boman, H.G. and Steele, B.B., (1970), J. Bact., 101, 218
- Mandelstam, J. and Rogers, H.J., (1959), Biochem. J., 72, 654
- Mandelstam, J. and Strominger, J.L., (1961), Biochem. Biophys. Res. Comm., 5, 466

- Mårdh, P.-A., Ripa, T., Andersson, K.-E. and Wadsö, I., (1976), Antimicrobial Agents and Chemotherapy, 10, 604
- Marshall, N.J. and James, A.M., (1971), Microbios, 4, 217
- Martin, E.L. and MacLeod, R.A., (1971), J. Bact., 105, 1160
- Mitsuhashi, S., Kobayashi, F. and Yamaguchi, M., (1971), J. Antibiot., 24, 400
- Monk, P.R. and Wadsö, I., (1968), Acta Chem. Scand., 22, 1842
- Monk, P.R. and Wadsö, I., (1975), J. Appl. Bact., 38, 71
- Morowitz, H.J., (1960), Biochim. biophys. Acta, 40, 340
- Neu, H.C. and Winshell, E.B., (1972), Antimicrobial Agents and Chemotherapy, 1, 107
- Newton, B.A., (1956), Bact. Rev., 20, 14
- Nomura, M., (1970), Bact. Rev., 34, 228
- O'Leary, G.P., Nelson, J.D.Jr. and MacLeod, R.A., (1972), Can. J. Microbiol., 18, 601
- Ortiz, P., (1970), Biochemistry, U.S.A., 9, 355
- Osborn, M.J., (1971), "Structure and function of biological membranes" (Academic Press Inc., New York), p.343
- Osborn, M.J., Gander, J.E. and Parisi, E., (1972a), J. Biol. Chem., 247, 3973
- Osborn, M.J., Gander, J.E., Parisi, E. and Carson, J., (1972b), J. Biol. Chem., 247, 3962
- Pechey, D.T. and James, A.M., (1974), Microbios, 10A, 111
- Pechey, D.T., Yau, A.O.P. and James, A.M., (1974), Microbios, 11, 77
- Prat, H., (1963), "Recent progress in microcalorimetry" (Pergamon Press, London), p.111
- Price, K.E., (1969), Advances in Applied Microbiol., 11, 17
- Roberts, N.A., Gray, G.W. and Wilkinson, S.G., (1970), Microbios, 2, 189

- Rogers, H.J. and Perkins, H.R., (1959), *Nature*, London, 184, 520
- Rolinson, G.N., Batchelor, F.R., Stevens, S., Cameron-Wood, J. and Chain, E.D., (1960), *Lancet*, ii, 564
- Rothfield, L. and Romeo, D., (1971), "Structure and functions of biological membranes" (Academic Press Inc., New York), p.251
- Russel, W.J., Farling, S.R., Blanchard, G.C. and Boling, E.A., (1975), "Microbiology - 1975", American Society for Microbiology, Washington, D.C., p.22
- Sabet, S.F. and Schnaitman, C.A., (1973), *J. Biol. Chem.*, 248, 1797
- Salton, M.R.J., (1952), *Biochim. biophys. Acta*, 9, 334
- Schnaitman, C.A., (1970a), *J. Bact.*, 104, 882
- Schnaitman, C.A., (1970b), *J. Bact.*, 104, 890
- Schnaitman, C.A., (1971), *J. Bact.*, 108, 553
- Senez, J.C. and Belaich, J.P., (1965), *Colloques int. Cent. natn. Rech. scient.*, 124, 357
- Seydel, J.K., (1968), *J. Pharm. Sci.*, 57, 1455
- Sinha, D.B. and Gaby, W.L., (1964), *J. Biol. Chem.*, 239, 3668
- Strominger, J.L., Park, J.L. and Thomson, R.E., (1959), *J. Biol. Chem.*, 234, 3263
- Vaczi, L., Makleit, J.K., Rethy, A. and Redai, I., (1964), *Acta Microbiol. Acad. Sci. Hung.*, 11, 383
- Washko, M.E. and Rice, E.W., (1961), *Clin. Chem.*, 7, 542
- Weidel, W., Franck, H. and Martin, H.H., (1960), *J. gen. Microbiol.*, 22, 158
- Weinstein, M.J., Leudeman, G.M., Oden, E.M. and Wagman, G.H., (1963), *Antimicrobial Agents and Chemotherapy* (American Soc. for Microbiology, Washington), p.1
- Wörsall, J., Lundquist, P.G. and Bjorkroth, B., (1969), *J. infectious Dis.*, 119, 410

White, D.A., Lennarz, W.J. and Schnaitman, C.A., (1972), J. Bact.,
109, 686

Wilkinson, S.G., (1967), J. gen. Microbiol., 47, 67

Wilkinson, S.G., (1970), J. Bact., 104, 1035

Winzler, R.J., (1941), J. cell. comp. Physiol., 17, 263

Zimelis, V.M. and Jackson, G.G., (1973), J. infectious Dis.,
127, 663